

Projector

**FP-ZUH12000**

**Owner's Manual**



# Advanced Manual

## Introduction

- ▶ Safety Precautions
- ▶ Package Contents

## Before You Begin

- ▶ Part Names and Functions
- ▶ Lens Adapter
- ▶ Lens
- ▶ Remote control
- ▶ Basic Operation
- ▶ Warping (Geometric Correction) and Edge Blending

## Installation

- ▶ Installation Overview
- ▶ Projection status adjustment
- ▶ Connecting to Other Devices

## Menu

- ▶ Menu List
- ▶ Using the Menu
- ▶ DISPLAY
- ▶ PICTURE
- ▶ SOURCE
- ▶ SYSTEM SETUP : Basic
- ▶ SYSTEM SETUP : Advanced
- ▶ STATUS

## Appendix

- ▶ Main Specifications
  - ▶ List of Supported Resolutions
  - ▶ Throw Distance List
  - ▶ Geometric Distortion Correction Area
  - ▶ PJLink Commands
  - ▶ Projector Control
  - ▶ Web Control
  - ▶ Trademarks
  - ▶ Licenses
-

# Safety Precautions

▼ For Your Safety

▼ Safe Use of Lasers

## For Your Safety

The ⚠️ **Warning** and ⚠️ **Caution** indications in this document represent the following:

⚠️ **Warning** Failure to observe warnings could result in death or serious injury.

⚠️ **Caution** Failure to observe cautions could result in injury or property damage.

This section lists important precautions that must be followed to ensure safe and correct use of the product. Read them before using the product and observe them during use.

### ⚠️ **Warning**

- Be sure the product is installed securely. Serious accidents could result should the product fall from a height.
- Mounting the product on a ceiling (Ceiling Mount INSTALLATION) must be performed by professional technicians with specialized skills. "If installed incorrectly, the product could fall, potentially causing a serious accident."
- When working in high places, always work with at least 2 people and ensure physical safety by using a safety line or other protective measures. "Slipping, falling, or loss of balance could result in serious accidents."
- "When installing the product in high places, ensure that people below keep their distance." Falling objects could cause serious accidents.
- Do not install or use the product in a bath or shower. Failure to observe this precaution could result in fire or electric shock.
- Do not handle the product with wet hands. Failure to observe this precaution could result in electric shock.
- "Do not modify, tug, or twist the power cables, subject them to excessive heat, or place them under heavy objects." Damage to the cables could result in fire or electric shock. "Should the cables be damaged, contact a Fujifilm-authorized service technician." Keep the cables clear of the intake and exhaust vents.

- Do not use cables if their connectors have ever been bent.
- Do not place the product on unstable surfaces. Be sure the product is level. Injury could result if the product tips or falls.
- Do not touch the metal parts of the product during thunderstorms. Lightning strikes can produce induced current that could cause electric shock.
- "Do not place vessels containing water, chemicals, or other liquids on the product." Liquid that finds its way into the product could cause fire or electric shock.
- Never look directly into the lens while the product is on. The bright light could cause visual impairment or other injury. "Do not look into the lens with magnifying glasses, telescopes, or other optical instruments"
- "Do not insert flammable material, metal, or other foreign objects into the product or leave them in its vicinity" "Failure to observe this precaution could result in fire, burns, or electric shock"
- Do not use sprays containing flammable gas to remove dust or other foreign matter from the lens. "The gases could ignite, causing fire."
- Do not use the product in locations where the air may contain flammable or explosive gases. "The gases could ignite, causing fire."
- Do not place flammable objects in front of the lens. Failure to observe this precaution could result in fire.
- "Do not block the light from the product with books, cloths, or other objects." "Objects placed in the beam could become hot, potentially melting or causing burns or fire." "Light reflected from the objects could also cause the lens to overheat, causing product malfunction"
- Do not touch the lens or metal parts of the product while it is on or immediately after it has been switched to standby. Failure to observe this precaution could result in burns or other injury.
- Be careful not to drop the product when lifting it.
- If an abnormality occurs, switch the power supply to the standby state (Standby) and disconnect the power cable. "Continuing to use the product when it is emitting smoke or unusual smells or otherwise functioning abnormally could result in fire, electric shock, or visual impairment."
- Use only the supplied power cable. Using other cables could cause overheating or an electrical short leading to fire or electric shock. Failure to properly ground the outlet to which the supplied power cable is connected could also result in electric shock.

## **Caution**

---

- Use the product only as described in this manual.
- The product and its accessories are precision devices. Under no circumstances should they be subjected to excessive force.
- When the product will not be used for an extended period, perform Mounting of the front lens cover on the Lens.
- The lens includes moving parts: do not apply excessive force or subject the lens to physical shocks.
- Do not install the product in locations with high humidity or dust, or in areas subject to oily smoke, steam, or vapors, or near heat sources. Using the product in these environments may cause malfunction, fire, or electric shock. Furthermore, oil can cause the resin casing to deteriorate, which may damage the mounting or support sections and lead to the main unit falling.
- Do not leave the product in locations where it will be exposed to high temperatures or direct sunlight. Failure to observe this precaution could result in fire.

- "Do not leave the product or, if the batteries are inserted, the remote control unattended in locations exposed to direct sunlight or high temperatures, for example directly in the path of warm air from a heater." "Excessive heat could deform the casing or damage the product's internal parts, resulting in fire."
- Do not place heavy objects on the product. "The objects could become unbalanced and tip or fall, causing injury."
- Do not use the power cable if the plug is damaged or does not fit securely into the socket. Failure to observe this precaution could result in fire or electric shock.
- "Keep your face and hands, as well as objects that may be warped or otherwise damaged by heat, away from the exhaust vent while the product is in use." The hot air from the vent could deform the objects or cause burns or accidents.
- "For safety, be sure to unplug the product when it is not in use." Failure to observe this precaution could result in fire due to deterioration of the insulation or other causes.
- Before transporting or cleaning the product, always switch the power supply to the standby state (Standby), unplug it from the power outlet, and disconnect all cables. Failure to observe this precaution could result in fire or electric shock.
- "When cleaning the product, do not use damp cloths or solvents such as alcohol, benzine (petroleum ether), or thinner." "Water could enter the product or the casing could weaken and break or suffer other damage, potentially resulting in electric shock."
- The accumulation of dust inside the product could result in fire or malfunction. We recommend that the interior of the product be periodically inspected and cleaned. Contact the original retailer for these services.
- Do not lift the product by the lens. This may cause a malfunction.
- When using the product at high altitudes (above approx. 1,500 m), set High Altitude Mode to "On" to ensure that the System Temperature is correctly adjusted. Failure to observe this precaution could shorten the life of the product's parts.
- Abnormalities such as smoke or unusual odors could lead to serious accidents, including fire, electric shock, or vision impairment. Immediately stop use, turn off the power supply and consult your dealer.
- Do not drop water or foreign objects into the product. Should water or other foreign matter enter the interior, switch the power supply to the standby state (Standby) and unplug it from the power outlet. Continued use could result in a short circuit causing fire or electric shock. Consult the original retailer.
- Do not disassemble or modify the product (never open the case). Failure to observe this precaution could result in fire or electric shock.
- Keep small parts out of the hands of infants and pets. "Because of their size, small objects such as batteries from the remote control may be accidentally swallowed by infants or pets." Keep small parts out of their reach. "Should an infant swallow any part of the product, consult a physician immediately"
- Keep safety in mind when stringing cables. Failure to observe this precaution could result in falls or injury.
- Do not install the product in locations subject to shock or vibration.
- Do not touch the lens immediately after switching the product to standby. Failure to observe this precaution could result in burns or other injury.
- Be sure the product is properly grounded.
- The plastic bags provided with this product present a suffocation risk when placed over the nose and mouth. Store them out of reach of infants and young children.

## **Precautions for Storage and Use**

---

- Do not use or store the product in locations subject to extreme temperatures. Avoid locations that are subject to sudden changes in temperature. Operate and store the product within its operating and storage temperature limits.
- Do not install the product in the vicinity of high-voltage power lines or equipment that produces magnetic fields. The product may not function as expected.
- Do not use the product when it is tilted. Failure to do so may result in malfunction or accidents.
- Do not touch the lens with your bare hands. Fingerprints and smudges on the lens can affect picture quality. To keep the Lens clean and prevent scratches, attach the front lens cover when the product is not in use.
- Remove the batteries from the remote control before placing it in storage. Leaving the batteries in place for long periods could result in leakage or other damage to the batteries.
- Do not use or store the product in locations exposed to oily smoke or tobacco smoke. Failure to observe this precaution could result in reduced picture quality.
- Malfunction or damage resulting from natural disasters (such as fire, earthquakes, floods, or lightning), pollution, salt damage, abnormal voltage, or use of a power supply at non-specified voltages or Frequencies will be subject to chargeable repair.
- To clean the lens, first put the projector into standby mode (Standby) and confirm that the lens and metal parts have cooled. Use a blower to remove dust and lint, then gently wipe the lens with a commercially available cleaning cloth.
- "When transporting the product, hold it by its base." Do not hold it by the lens or the opening around the lens. Failure to observe this precaution could damage the product.
- "Thread-locking adhesive, lubricants, or grease on the ceiling mounts could cause the projector's plastic casing to deteriorate, potentially damaging the product or causing it to fall."
- Do not install or store the product where it will be exposed to salt damage or corrosive gases. Corrosion could damage the product or cause it to fall.
- When transporting the product, be sure to remove the Lens beforehand.
- When storing this unit, always ensure the adapter cap is attached.

## Safe Use of Lasers

This product is classified as "CLASS 1 LASER PRODUCT – RISK GROUP 2" according to IEC 60825-1:2014, and further complies with 21 CFR 1040.10 and 1040.11. However, compliance as a Risk Group 2 LIP as defined in IEC 62471-5:Ed.1.0 is excluded. For advanced details, refer to "Laser Notice No. 57" dated May 8, 2019.

Projectors equipped with A22 and A23 Lens (throw ratio exceeding 2.4) may be classified as Class 1 Laser Product-Risk Group 3 (RG3); these are for professional use only and are not intended for general consumers. Operators must control access to the beam within the hazard distance (HD) or perform the INSTALLATION at a height that prevents eye exposure within the hazard distance (HD).



IEC 60825-1:2014

CLASS 1 LASER PRODUCT

This product is for professional use and is designed to project an IMAGE onto a wall or screen.

Be sure to observe the following warnings and cautions.

Lens	Throw ratio	Classification and Requirements for Laser Illumination Projectors (LIP)	
FP-ZL034	0.34–0.41	HD: N/A	IEC 62471-1: 2015 IEC 60825-1: 2014

FP-ZL050	0.50–0.65	CLASS 1 LASER PRODUCT RISK GROUP 2
FP-ZL125	1.25-2.00	

## Warning

- This product contains a laser; do not open the case.
- This projector has built-in Class 4 laser module. Disassembly or modification is very dangerous and should never be attempted.
- Bright light can cause visual impairment or other injury; do not look directly at the light source. "In the event that you do look directly at the light source, consult a physician as required."
- Never attempt to remodel or disassemble the projector. High voltages can cause fire or electric shocks.

## Caution

- Dispose of this product in accord with location regulations; do not disassemble.
- Use of controls or adjustments or performance of procedures other than those specified herein may result in hazardous radiation exposure.
- "As with any bright source, do not stare into the direct beam, RG2 IEC 62471-5:2015"

Lens RG2



Caution: Hot surface, do not touch

- "Do not place your hands, face, or other objects in front of the projector lens while the projector is operating." Objects can become extremely hot, potentially resulting in fire or damage caused by the heat emitted from the Light Output Settings. Things placed in front of the lens may overheat and burn or start a fire.
- Do not spray flammable gas to get rid of dust and dirt that accumulate in the lens. Doing so could cause a fire.

## Notes on the Laser

"This product uses a laser as a light source, which has the following characteristics:"

- The light source may dim under certain conditions.
- "The higher the temperature, the more the source will dim."
- The source will grow dimmer the longer it is used.
- The relation between source brightness and length of use can be adjusted using brightness settings.
- "To prevent exposure to harmful laser light, consult an authorized service center should the projector require inspection, adjustment, or repair."
- The projector is equipped with a built-in laser module. Follow the instructions in the product manual when operating the projector or adjusting settings.

- Be sure to remove the front lens cover before turning the power supply on. The front lens cover may be damaged if left in place while the Projector power supply is On and the laser light source is active.
- Ensure that children do not stare into the projector light source.
- "Before turning the projector on, check to be sure that no one is standing in front of the lens."
- Do not use optical instruments such as telescopes or binoculars while the projector is in operation.

## Laser Warning Stickers

---

The laser Warning label is affixed to the bottom/side of the product.

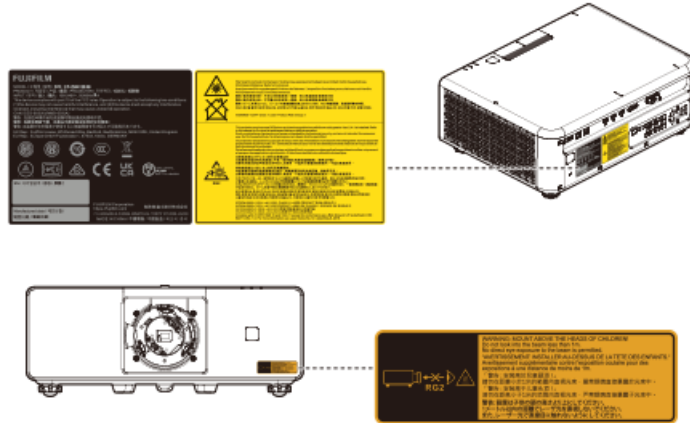

Rating label stickers

Product label (rating label) attached to the side of the product.

## Specifications of Laser Source

---

### ■ FP-ZUH12000

- **Wavelength:** 455 nm
- **Maximum output:** 342 W

# Package Contents

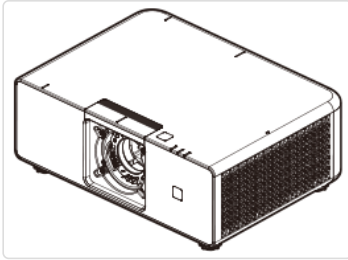

Projector



Remote control, AAA batteries  
(x2)

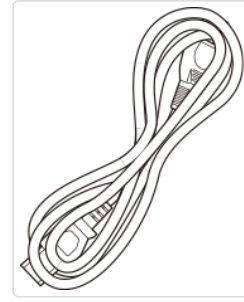

Power cable (3.0 m)



Quick start guide

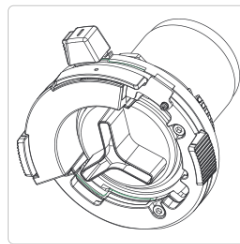

Lens adapter (pre-installed on  
the main unit; includes adapter  
cap)

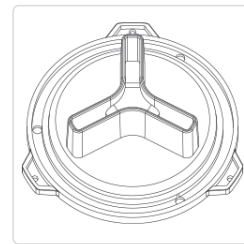

Body cap

# Part Names and Functions

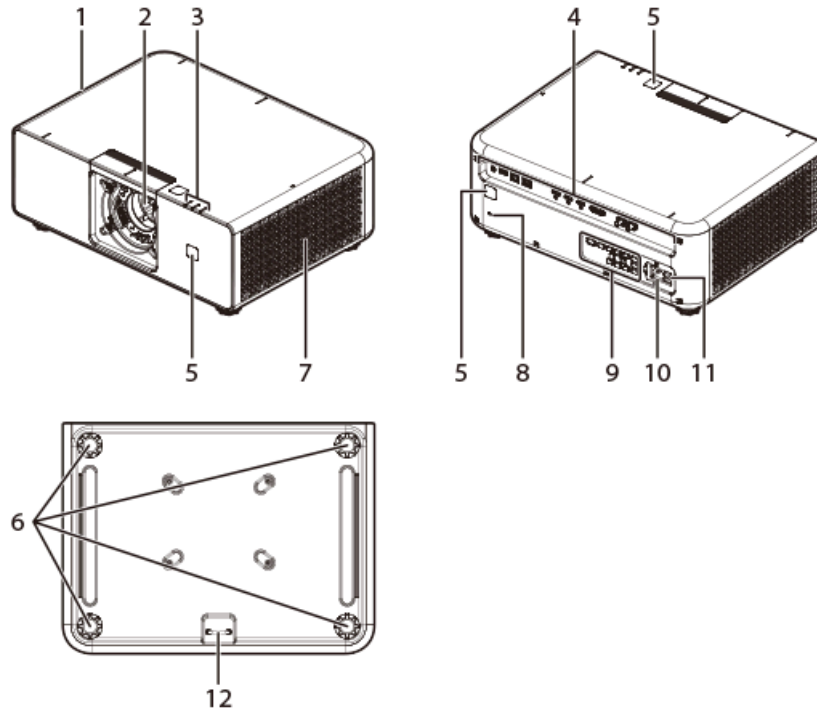

No.	Name
1	Intake vents
2	Lens Mounting Section
3	Indicator Lamps
4	Connectors
5	Remote receiver
6	Adjustable feet

No.	Name
7	Exhaust vent
8	MicroSaver Security System® PIN Slot
9	Control panel
10	Power connector
11	Main power
12	Security lock

▼ [Control panel](#)



▼ [Connectors](#)

▼ [Indicator Lamps](#)

# Control panel

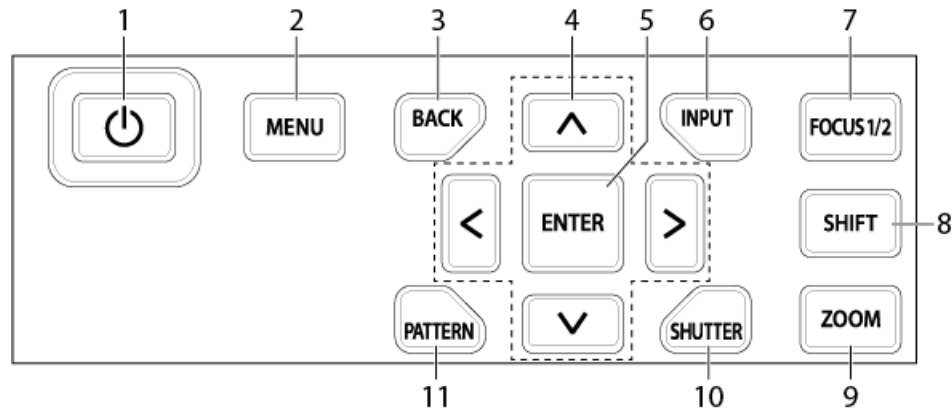
Basic operations are performed using the control panel. The names and functions of the buttons on the control panel are given below.



No.	Button Name	Description
1	 (Power)	Turns the unit on or puts it in standby mode.
2	<b>MENU</b>	Displays the menu screen for various settings and adjustments.
3	<b>BACK</b>	Returns to the previous menu level during menu operation.
4	 (Selector)	Used for menu operation.
5	<b>ENTER</b>	Confirms the item selected during menu operation.
6	<b>Input</b>	Switches between input devices.
7	<b>FOCUS1/2</b>	Switch between FOCUS1/2 to adjust the focus.
8	<b>Shift</b>	Adjusts lens shift.
9	<b>ZOOM</b>	Adjusts lens zoom.
10	<b>SHUTTER</b>	Temporarily mutes the image and audio. Press the button again to resume projection.
11	<b>TEST PATTERN</b>	Display a Test Pattern and switch between patterns using the  arrow keys.

# Connectors

Connect the cables to the appropriate connection terminals for the devices being connected.

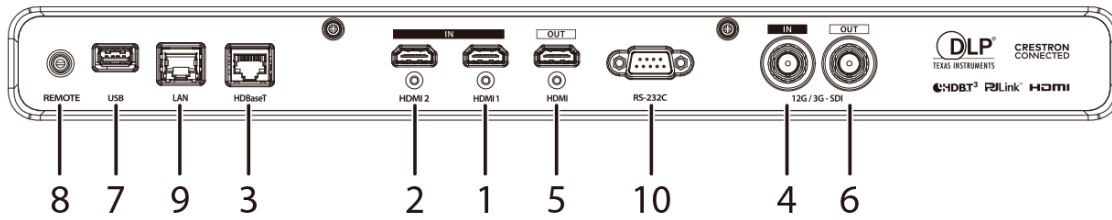

Connection Name		Description		
VIDEO IN	1	HDMI® 1	Type A	HDMI® 2.0, HDCP 2.3 compliant
	2	HDMI® 2	Type A	HDMI® 2.0, HDCP 2.3 compliant
	3	HDBaseT	RJ-45	HDBaseT™ 3.0 compliant
	4	12G/3G-SDI	BNC	12G/3G SDI compatible
VIDEO OUT	5	HDMI®	Type A	HDMI® 2.0, HDCP 2.3 compliant
	6	12G/3G-SDI	BNC	12G/3G SDI compatible
For control	8	REMOTE	3.5mm stereo mini jack	For remote control (wired)
	9	LAN	RJ-45	For network connection, 10Base-T/100Base-TX
	3	HDBaseT	RJ-45	For projector control
	10	RS-232	D-Sub 9-pin male	For projector control
OTHER	7	USB	Type A	DC 5V 2A (maximum) power supply, for maintenance

#### Caution





- Before connecting, ensure that this unit and all connected devices are in standby mode. After all connections are complete, turn on this unit first, and then turn on the connected devices.
- Depending on the device, a dedicated cable, conversion plug, or adapter may be required.

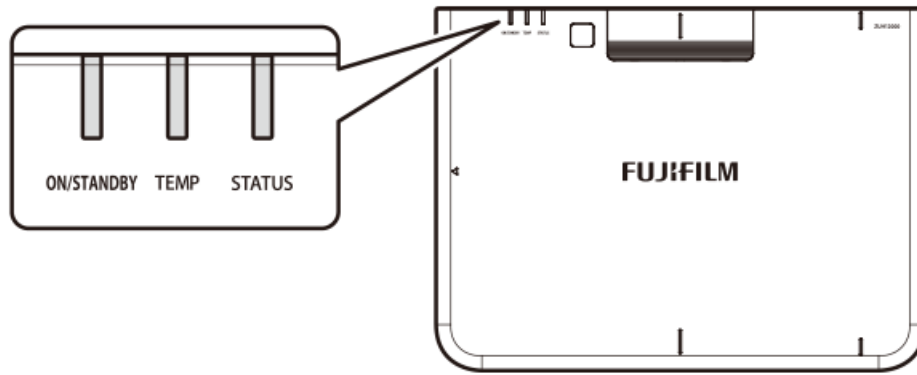









## Indicator Lamps

The projector status can be determined by the lit, flashing, or off states of the indicator lamps (ON/STANDBY, TEMP, STATUS).



The indicator lamp patterns and the corresponding projector status are as follows.

Lamp			Projector status
ON/STANDBY	TEMP	STATUS	
RedSteady	-	-	Standby state (Standby)
GreenFlashing 1	-	-	Starting up
GreenSteady	-	-	POWER ON
RedFlashing 1	-	-	Standby state (Network Standby)
-	 OrangeFlashing 1	-	Shutting down
GreenSteady	GreenSteady	-	shutter function on
-	GreenFlashing 2	-	Communicating
-	 OrangeGreen Flashing 3	-	Firmware update in progress
GreenSteady	GreenSteady	GreenSteady	Firmware update starting
 OrangeFlashing 1	 OrangeFlashing 1	-	Firmware update standby
RedSteady	GreenSteady	-	Factory Reset
GreenSteady	RedFlashing 1	 OrangeFlashing 1	Main unit temperature rise
GreenFlashing 2	-	 OrangeFlashing 2	Laser light source error
GreenFlashing 2	RedFlashing 1	 OrangeFlashing 2	DMD Error
-	-	 OrangeSteady	Fan 1 Error
-	-	 OrangeFlashing 1	Fan 2 Error

-	-	 OrangeFlashing 2	Fan 3 Error
GreenSteady	-	 OrangeSteady	Fan 4 Error
GreenSteady	-	 OrangeFlashing 1	Fan 5 Error
-	RedSteady	 OrangeSteady	Fan 8 Error
-	RedSteady	 OrangeFlashing 1	Fan 9 Error
-	RedSteady	 OrangeFlashing 2	Fan 10 Error
GreenFlashing 1	RedSteady	-	Fan 11 Error
GreenFlashing 1	-	 OrangeFlashing 1	Filter wheel Error
GreenFlashing 1	-	 OrangeFlashing 2	phosphor wheel error
 OrangeSteady	-	 OrangeSteady	Power error

 **Note**

The LED indicator supports three flashing modes:

- Flashing 1: Flashes once every 0.5 s.
- Flashing 2: Flashes once every 0.04 s.
- Flashing 3: Two colors alternate every 0.5 s.
- "If error occur, please contact the place of purchase."

# Lens Adapter

Depending on the projection lens used, lens adapter mounting and removal may be required. A lens adapter is required for projection lenses that have "A" marked on the serial label.



## Projection Lenses Requiring a Lens Adapter

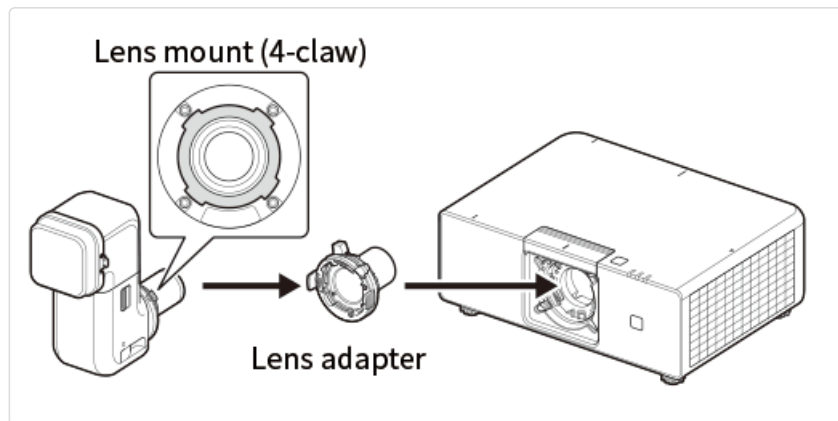

## Projection Lenses Not Requiring a Lens Adapter

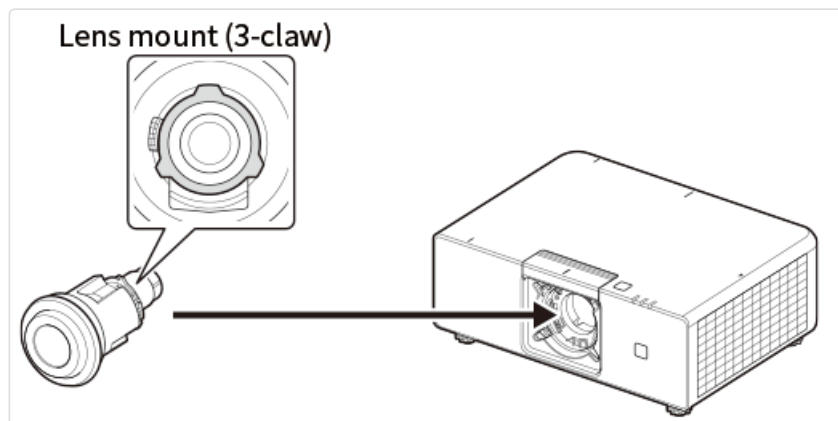

The lens adapter is attached to the projector body at the time of shipment.

- ▼ When using a lens adapter
- ▼ When not using a lens adapter

## When using a lens adapter

If the lens mounting section appears as shown in the illustration, the lens adapter is already installed. No installation of the lens adapter is required.

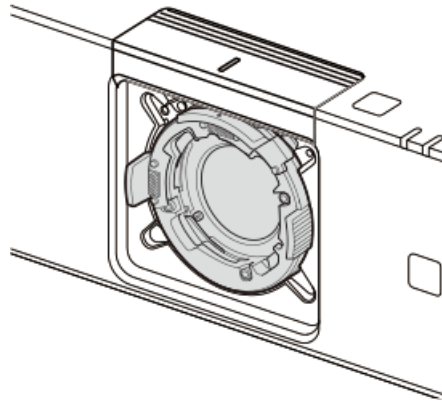

## Removing the lens replacement cover and body cap

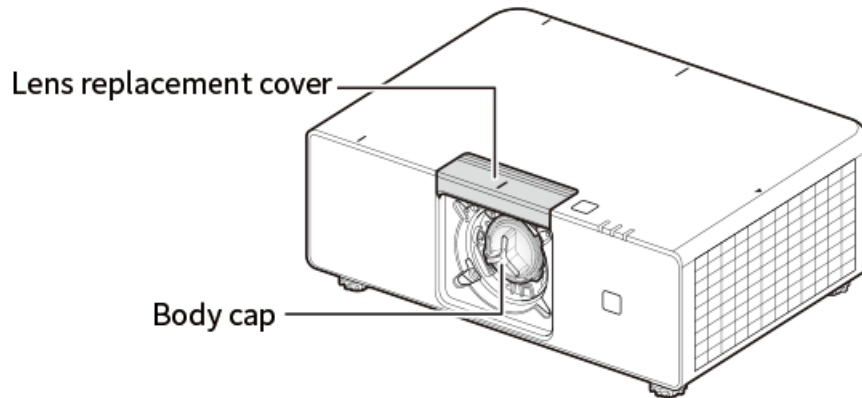

- 1** While simultaneously pressing the positions indicated by ① on the lens replacement cover, pull the cover in direction ②.

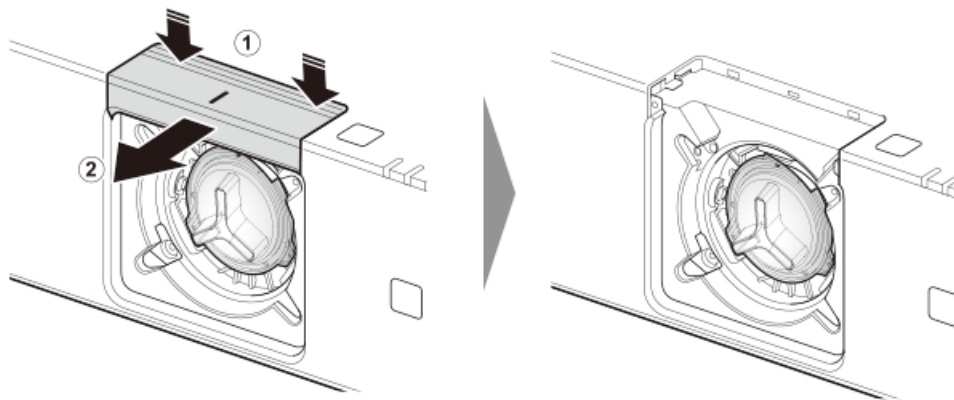

- 2** Rotate the body cap counterclockwise to remove it.

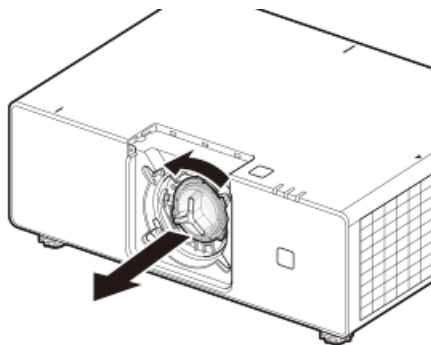

## Removing the adapter cap

Remove the adapter cap before mounting the lens adapter

- 1** Grasp the lens adapter lever knob from both sides with your fingers.

- 2** Move the lever in the direction of the arrow until it stops.

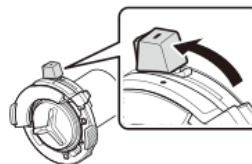
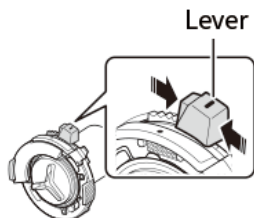

- 3** Pull the adapter cap in the direction of the arrow to remove it.

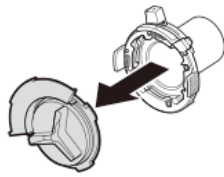

## Lens adapter mounting

- 1** Grasp the lens adapter lever and rotate it clockwise until it stops. Confirm that the lever is to the right of the center when viewed from the front.

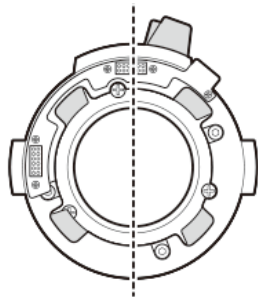

- 2** Insert the lens adapter. Align the index (red line) on the lens adapter lever knob with the index (red circle) on the projector body.

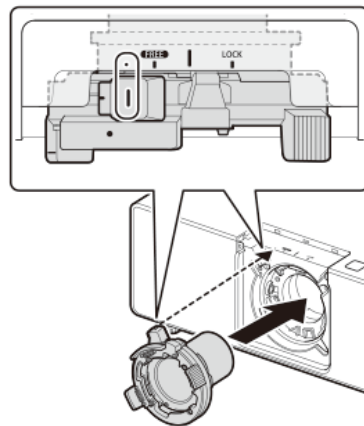

- 3** Rotate the lens adapter clockwise until it comes to a stop. Rotate the lens adapter lever knob until its index (red line) aligns with the LOCK position on the projector body.

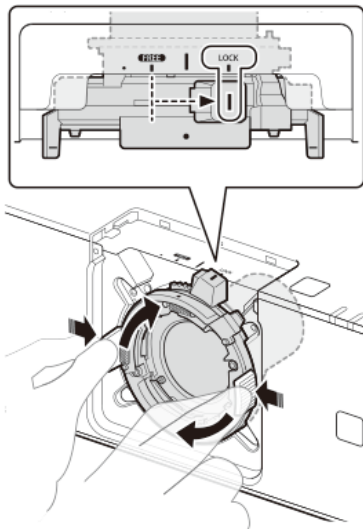

- 4** Using a screwdriver, tighten the two lens adapter fixing screws shown in the figure by rotating them clockwise.

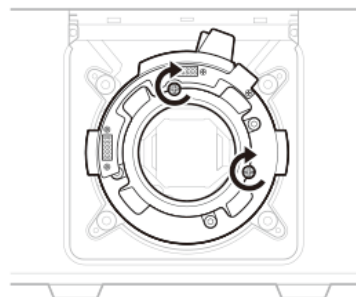

- 5** Grasp the lens adapter lever knob from both sides with your fingers and move it in the direction of the arrow until it stops.

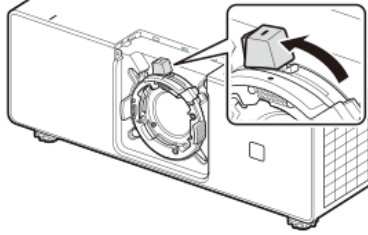

- 6** Using a screwdriver, tighten the lens adapter fixing screw shown in the figure by rotating it clockwise.

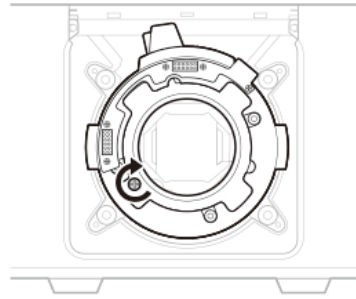

- 7** If no projection lens is to be installed, attach the adapter cap to prevent dust entry. To attach the cap, follow the reverse procedure of step 5, "Removing the adapter cap."

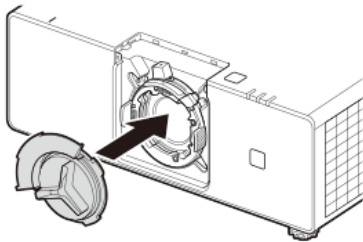

**⚠ Caution**

The projection lens cannot be mounted unless all three lens adapter fixing screws are tightened; ensure they are tightened securely.

## When not using a lens adapter

If the lens mounting section appears as shown in the figure, the lens adapter has already been removed.

The lens adapter attachment/detachment procedure is not required.

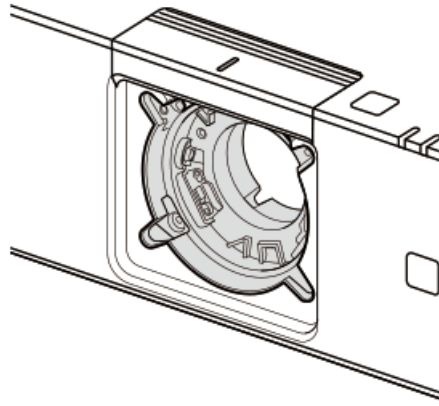

## Removing the lens replacement cover

---

Lens replacement cover

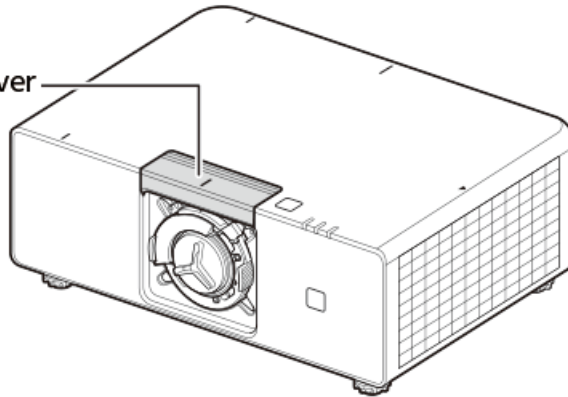

- 1 While simultaneously pressing the positions indicated by ① on the lens replacement cover, pull the cover in direction ②.

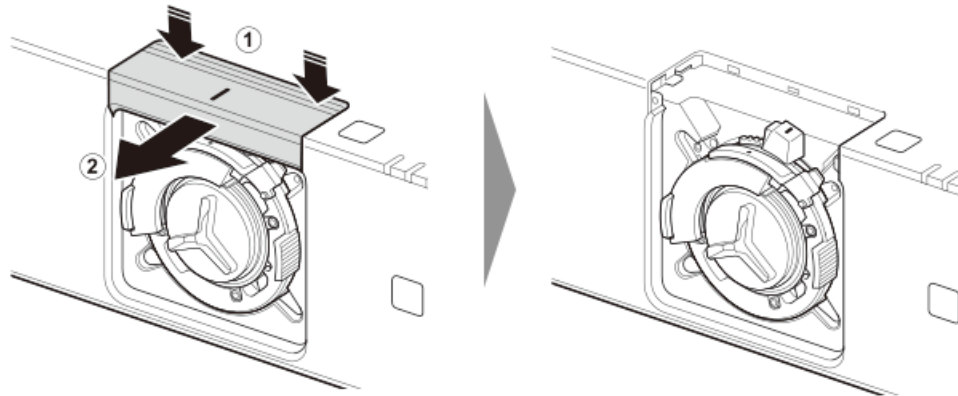

## Removing the adapter cap

---

- 1 Grasp the lens adapter lever knob from both sides with your fingers.
- 2 Move the lever in the direction of the arrow until it stops.

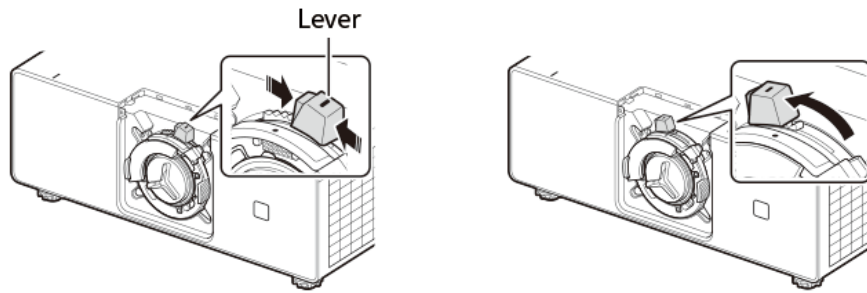

- 3** Pull the adapter cap in the direction of the arrow to remove it.

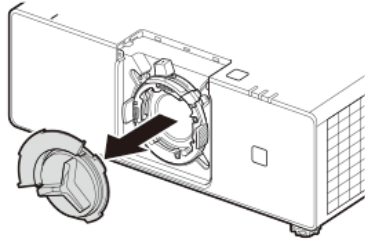

## Loosening the lens adapter fixing screws

There are three lens adapter fixing screws; the position of the lever must be changed to loosen all of them. Follow the procedure below.

- 7** Using a screwdriver, turn the screw at the location shown in the figure counterclockwise until it rotates freely.

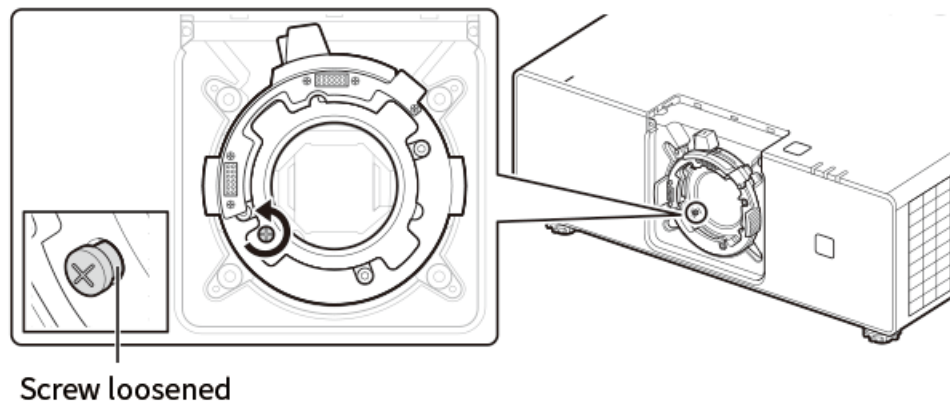

- 2** Grasp the lens adapter lever knob from both sides with your fingers and move it in the direction of the arrow until it stops.

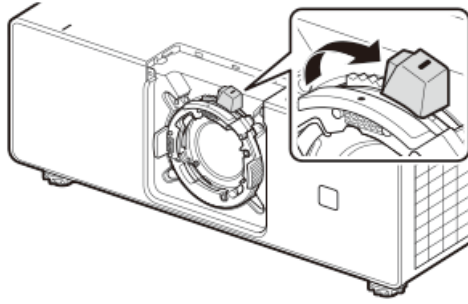

- 
- 3** Using a screwdriver, turn the two screws shown in the figure counterclockwise to loosen them until they spin freely.

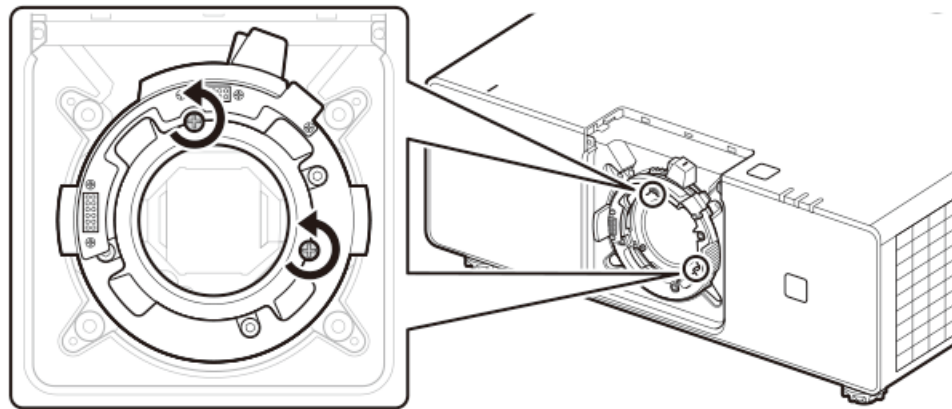

## **Removing the lens adapter**

---

- 7** Hold the lens adapter handles with both hands and rotate it counterclockwise (approximately 35 degrees). Rotate the lens adapter lever knob until the index (red line) aligns with the index (red dot) on the projector body.

Up to the position where the indicator on the lens adapter lever aligns with the indicator on the projector

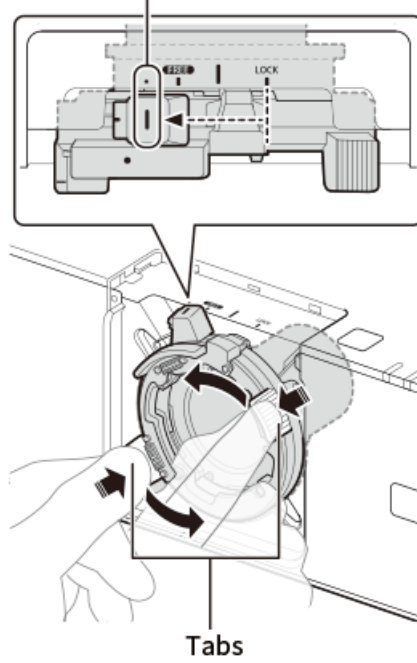

**2** Pull out the lens adapter

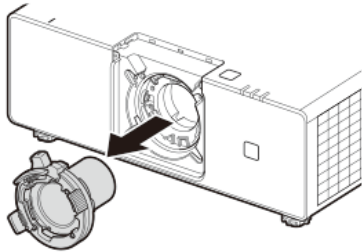

**3** Attach the lens replacement cover from the direction of the arrow.

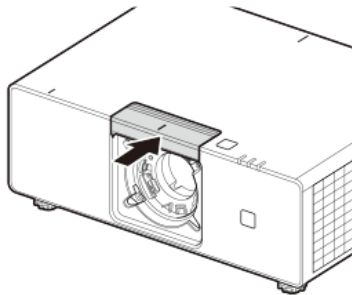

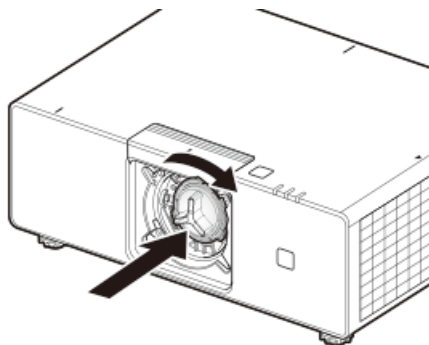

**4** If a projection lens is not being installed, attach the body cap to prevent dust entry.



# Lens

Depending on the projection lens used, lens adapter mounting and removal may be required. For details, refer to [👉 “Lens Adapter.”](#)

## ■ Available projection lenses

Model name	 FP-ZL034	 FP-ZL050	 FP-ZL125
lens adapter	Required	N/A	N/A
Lens Shift	Motorized: V (vertical) ±60%, H (horizontal) ±30%	Motorized: V (vertical) ±53%, H (horizontal) ±25%	Motorized: V (vertical) ±55%, H (horizontal) ±25%
ZOOM	Motorized: 1.0x–1.2x	Motorized: 1.0x–1.3x	motorized zoom: 1.0x–1.6x
TR value*1	0.34 (wide end)–0.41 (tele end)	0.50 (wide end)–0.65 (tele end)	1.25 (wide end)–2.0 (tele end)
F-number	F2.2 (wide end) – F2.41 (tele end)	F2.0 (wide end) – F2.2 (tele end)	F2.0 (wide end) - F2.33 (tele end)
External dimensions	Width 128 × Length 341 mm	ø164 × 247 mm (length)	ø138 × 217 mm (length)
Weight	Approx. 4.5 kg	Approx. 2.3 kg	Approx. 1.9 kg

\*1 The TR (throw ratio) value is calculated by dividing the projection distance by the screen width.

▼ [Attaching and Removing the FP-ZL034 Projection Lens](#)

▼ [Attaching and Removing the FP-ZL050/FP-ZL125 Projection Lens](#)

## Attaching and Removing the FP-ZL034 Projection Lens

The ZP-ZL034 projection lens requires a lens adapter. Attach the lens adapter in advance.  
For details, refer to [“Lens Adapter.”](#)

## Supported Mounting Directions

The FP-ZL034 projection lens can be attached to the lens adapter in two directions as shown in the figure below.

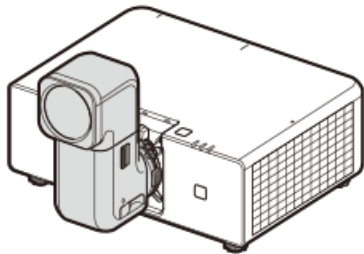

90 degrees

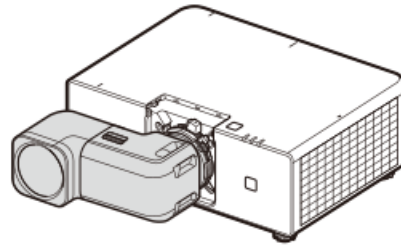

0 degrees

Regarding the mounting direction, the projection lens can only be mounted when the projection lens mounting indicator is aligned with the lens adapter mounting indicator.

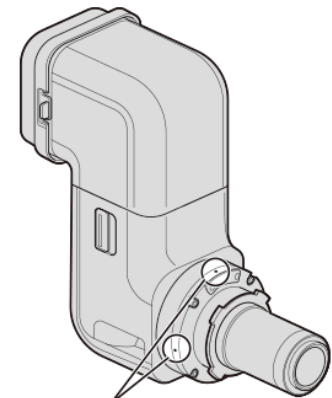

Projection lens attaching alignment mark (white)

Lens adapter alignment line (white)  
Projection lens alignment line (silver)

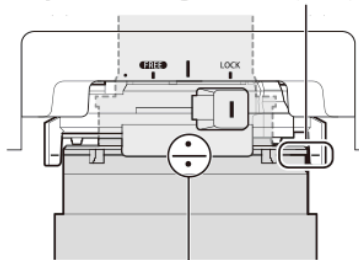

Lens adapter alignment mark (white)  
Projection lens attaching alignment mark (white)

### Caution

When mounting or removing the projection lens, hold it by the projection lens mount area. In particular, avoid holding the top of the FP-ZL034 bent-type projection lens. Failure to do so may cause lens damage.

## Projection lens mounting

Before mounting, confirm that the lens adapter lever is in the FREE position and that the three lens adapter fixing screws are recessed behind the lens mounting surface (the screws should be tightened into the projector body).

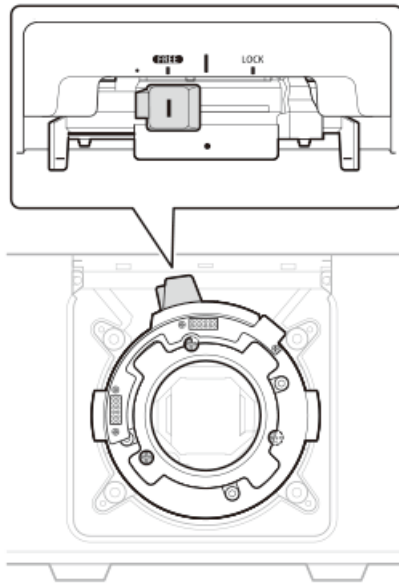

**1** Remove the projection lens rear cover, determine the desired mounting direction, and insert the lens straight into the projector body.

\* Perform this with the lens front cover still attached.

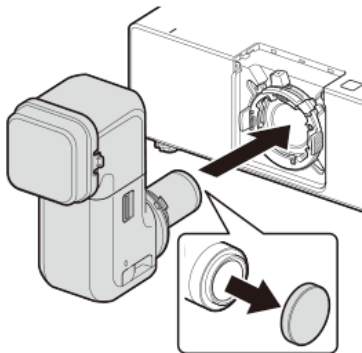

**2** Confirm that the lens is inserted to the position where the lens adapter index line and the projection lens index line are aligned.

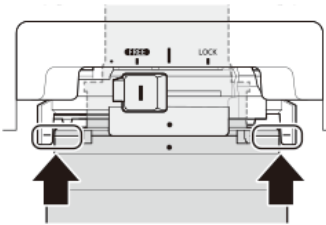

If the projection lens cannot be inserted up to the index line, the following may be the cause.

①. The lens adapter fixing screw is not tightened.

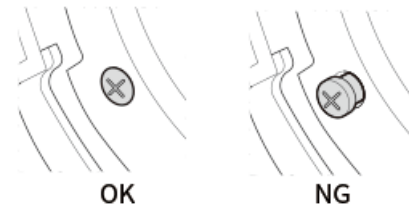

②. The projection lens is inserted in a direction other than the specified direction.

**3** Move the lens adapter lever to the LOCK position.

\* The lever will not move if the

**4** Mount the lens replacement cover.

Place the lens replacement cover on the projector body and

projection lens is not inserted correctly.

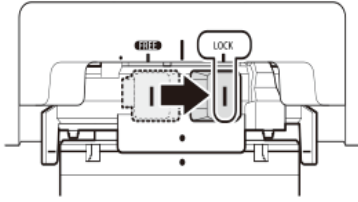

press it in the direction of the arrow to mount it.

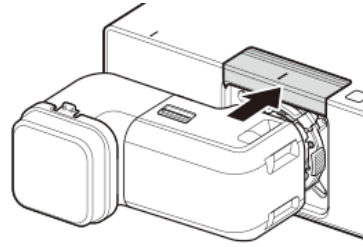

**5** Remove the lens front cover.

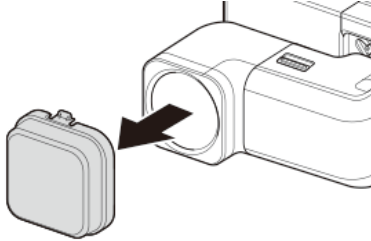

## Removing the projection lens

---

To remove the projection lens, follow the Mounting procedure in reverse.

**1** Attach the lens front cover.

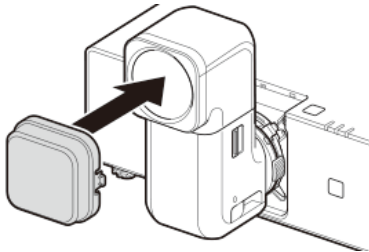

**2** Move the lens adapter lever to the FREE position.

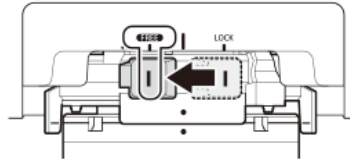

**3** Pull out the projection lens.

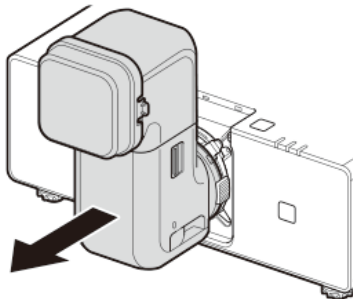

## lens axis lock lever

---

The FP-ZL034 projection lens is rotatable and equipped with a lock mechanism on the lens axis. Rotate it using the following procedure. Be sure to engage the lock during projection.

**⚠ Caution**

- Vignetting may occur depending on the projection direction and lens shift adjustment.
- When rotating the lens, support the lens unit and rotate it slowly.
- When changing the lens orientation, pay close attention to the surroundings. If projected light enters the eyes, it may cause vision impairment or other injuries.

Sliding the lens axis lock lever to **FREE** to unlock it allows the lens unit to be rotated 360° in 90° increments around the lens axis. After rotating, be sure to set the lock lever to **LOCK**.

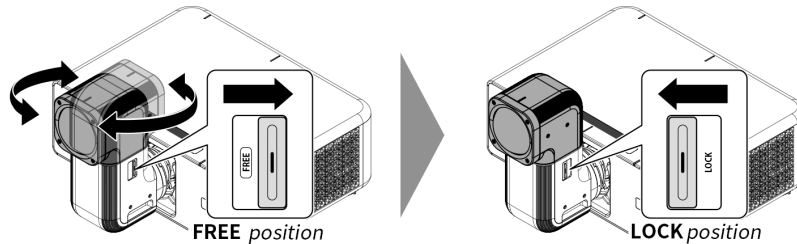

Setting the lens axis lock lever to **FREE** allows the lens to rotate, and setting it to **LOCK** engages the lock.

## Precautions for transport

**⚠ Caution:** When transporting the projector, be sure to hold it by its base. Do not hold it by the lens or the opening around the lens. Failure to observe this precaution could damage the product.

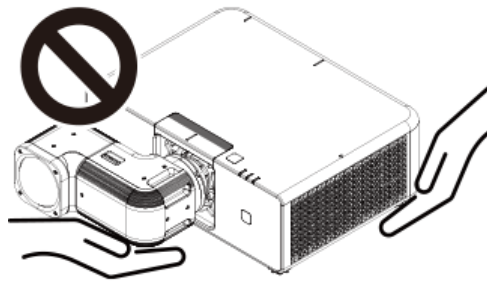

## Attaching and removing the FP-ZL050/FP-ZL125 projection lens

The FP-ZL050/FP-ZL125 projection lens does not use a lens adapter. Remove the lens adapter in advance.

For details, refer to [👉 "Lens Adapter."](#)

## projection lens mounting

---

The projection lens can be mounted without removing the lens replacement cover.

Remove the projection lens rear cover, align the surface marked TOP with the top surface of the projector body and insert it straight (①), then rotate the projection lens clockwise until it stops (②).

\* Rotation should be approximately 35 degrees.

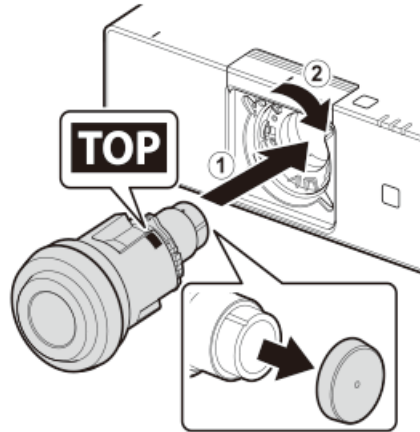

## Removing the projection lens

---

To remove the projection lens, follow the Mounting procedure in reverse.

**1** Attach the lens front cover.

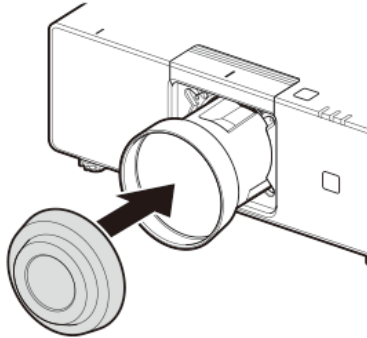

**2** Rotate the projection lens counterclockwise until it stops (①), then pull out the projection lens (②).

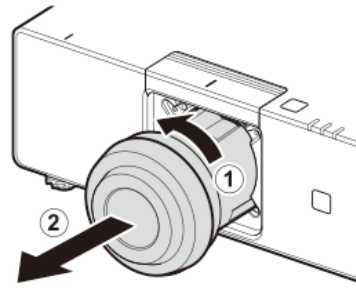

# Remote control



- ▼ [Remote Control Button Names and Functions](#)
- ▼ [Remote Control Reception Range](#)
- ▼ [How to Set the ID Number](#)

## Remote Control Button Names and Functions

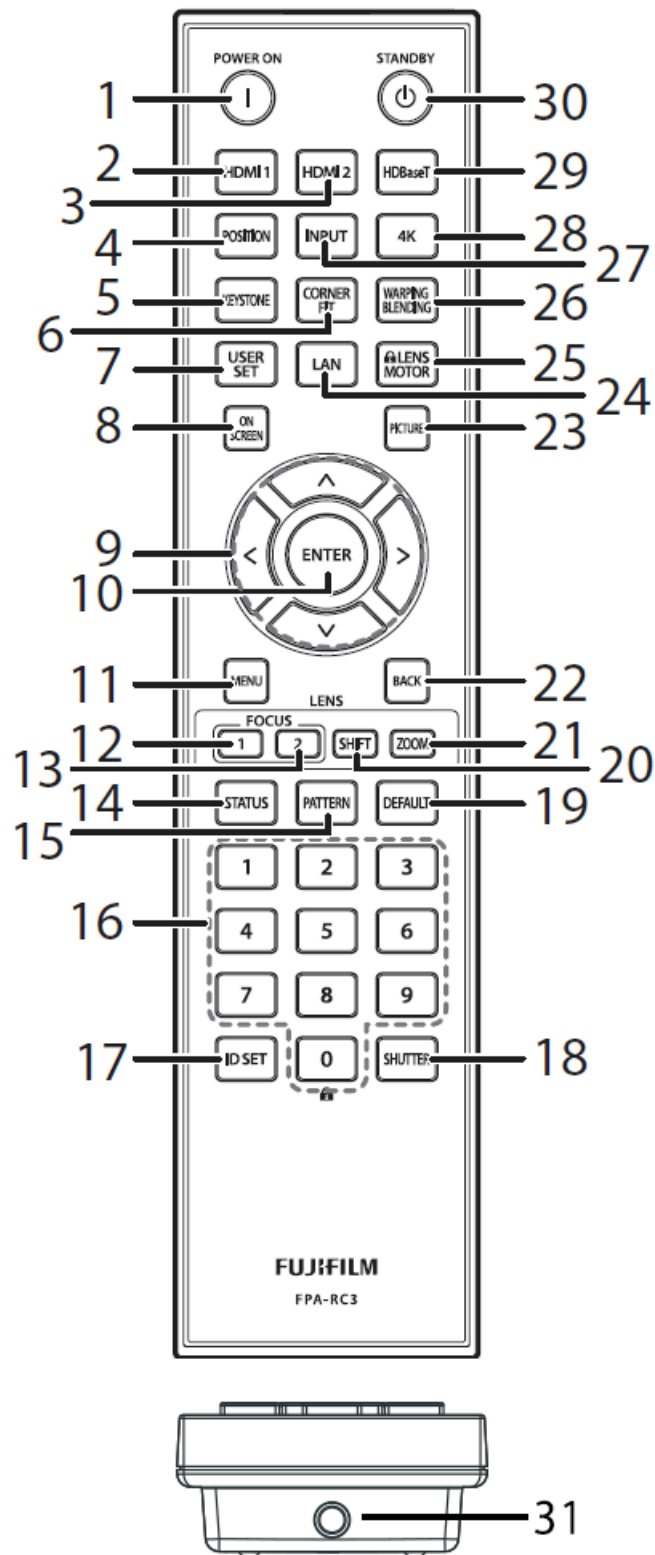
The names and functions of the remote control buttons are as follows.



No.	button name	Description
1	POWER ON	Turn the power supply On.
2	HDMI®1	Select HDMI® 1.
3	HDMI® 2	Select HDMI® 2.
4	POSITION	Select the projector position.

5	KEYSTONE	Adjusts keystone correction.
6	CORNER FIT	Adjust the four corners of the image individually
7	USER SET	Enter user settings menu.
8	ON SCREEN	Turns the menu display off. Press the button again to turn the menu display on.
9	 (selector)	Used for menu operation.
10	ENTER	Confirms the item selected during menu operation.
11	MENU	Displays the menu screen for various settings and adjustments.
12	FOCUS1	Lens adjustment: Adjusts the overall focus.
13	FOCUS2	Lens adjustment: adjusts the peripheral focus.
14	STATUS	Displays information about the projector.
15	PATTERN	Display a test pattern. Switch patterns using the   keys.
16	<b>Numeric keypad "0": Remote control operation lock</b>	Press and hold for 4 s to disable remote control operation. When locking remote control operation, point the remote control at the light receiver on the main unit. This function can be operated only with the remote control.
17	ID SET	The unit ID and remote control ID are displayed on the screen.
18	SHUTTER	Temporarily turns off the image. Press the button again to resume projection.
19	DEFAULT	Restores the selected menu item to its factory default settings. This function can only be operated using the remote control.
20	SHIFT	Adjusts the lens shift.
21	ZOOM	Adjusts the lens zoom.
22	BACK	Returns to the previous menu level during menu operation.
23	PICTURE	Switches the picture mode setting.
24	LAN	Goes to the LAN setup menu.
25	LENS MOTOR	Enables or disables the lens adjustment function. (focus adjustment, shift adjustment, and zoom adjustment operations)
26	WARPING BLENDING	Displays the geometric distortion correction/Blend Settings setup menu.
27	INPUT	Displays the input menu.
28	4K	Switches 4K mode On/Off.

29	HDBaseT™	Select HDBaseT™.
30	STANDBY	Switches the projector to standby mode.
31	Remote Output	To use a wired remote control, connect it to the Remote In terminal of the projector using a commercially available ø3.5mm stereo mini-jack cable.

 **Note**

When the remote output terminal is used, infrared signals are not emitted from the remote control.

## Remote Control Reception Range

The reception ranges for the projector's three remote control receivers are as follows:

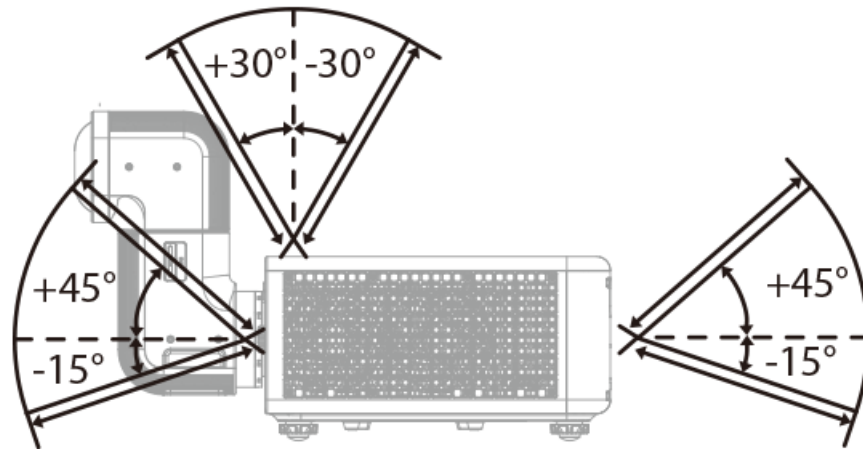

- **Angle:**  $\pm 30^\circ$ ,  $-15^\circ$  to  $45^\circ$
- **Distance:** Maximum 12 meters (39 feet)

## How to Set the ID Number

By setting the remote control ID number, you can operate multiple projectors simultaneously or individually with a single remote control.

### Example: Set ID "02"

**7** Set the projector ID.

The projector ID default setting is "Off".

- ① Select **projector ID setup** (**system settings: basic** menu).

- ② Select **On** for **projector ID setup** in the ID selection display screen. Next, select "02" and press **ENTER** to confirm.

## 2 Set the remote control ID.

The remote control ID default setting is 00.

- ① : Press and hold ID SET on the remote control for 3 s.

➔ The remote control operation backlight flashes for 3 s and then stays lit.

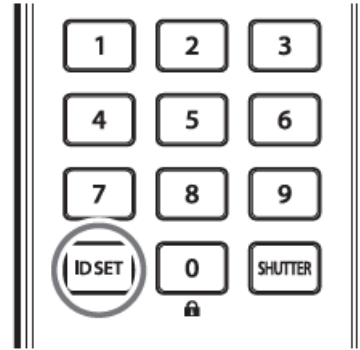

- ② : Press "0" on the 10-key button within 3 s, and then press "2" within 3 s.

- ③ : Press ENTER within 3 s.

➔ The remote control operation indicator light turns off.

### **Caution**

"Once the operation is complete, check that the IDs on the projector and remote control are correct."

Pressing ID SET on the remote control displays the remote control ID (Basic System Setup -> projector ID setup).

### **Note**

If Projector ID is Off, the projector can be operated with any remote control ID from "00" to "99".

# Basic Operation

## Connecting the Power Cable

Connect the supplied power cable to the projector and engage the cable lock hook. Ensure that the cable lock hook is securely engaged in the designated position.

Plug the cable into an outlet

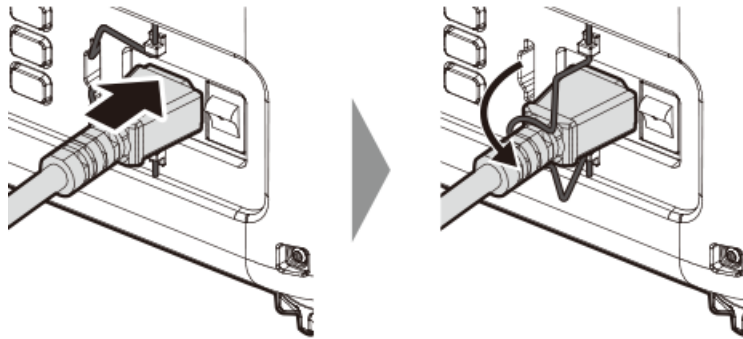

### ⚠ Caution

Be sure to use only the supplied power cable. The supplied power cable is for use exclusively with this unit.

Do not use it with any other devices.

Plug it into a 3-pin outlet.

## Powering On

- 7 Turn the power switch on. The projector enters the standby state. The indicator lamp will turn red (lit/flashing).

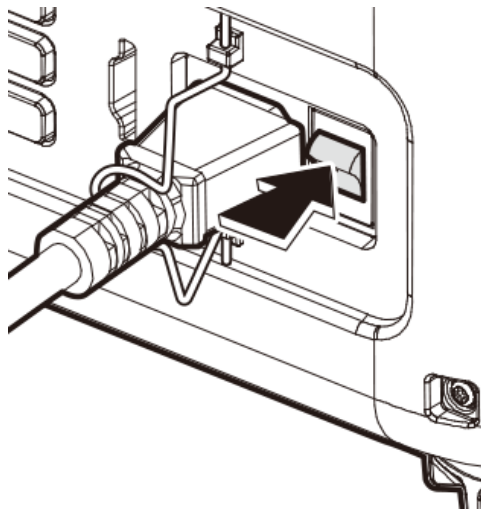

- 2** Press the power button to power on. The indicator lamps will light green. An image will be projected after a short while.



Remote control

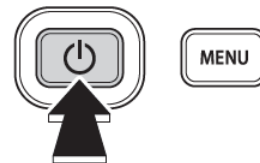

Main unit

**⚠ Caution**

Do not look directly into the lens while the projector is on.

## Putting the Projector into standby mode

If the power button (or the standby button on the remote control) is pressed while the projector is powered on, a confirmation message is displayed. Press the power button again to put the projector into standby mode (Standby). The cooling fan stops a few seconds after the projector enters standby mode (Standby).



Remote control

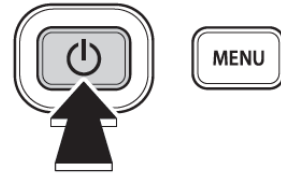

Main unit

# Warping (Geometric Correction) and Edge Blending

Using geometric distortion correction allows you to project onto surfaces such as a curved screen or project a single image using multiple projectors.

## Types and Limitations of warping and edge blending

This unit is equipped with two types of warping and edge blending function: one configured via the remote control from the operation menu, and another configured using a dedicated application installed on a PC.

Differences between the geometric distortion correction function are as follows.

No.	Application Version	Operation menu version
<b>Operation Method</b>	Operate via a dedicated application installed on a PC (LAN environment required)	Operation via remote control
<b>Maximum warping grid number</b>	65* × 33 (*If 65, the frame rate is up to 60Hz)	17 × 17
<b>Grid point movement</b>	Single point, multiple points, or per line	Single point
<b>Black Level Correction</b>	On	None
<b>Mask Function</b>	On	None
<b>Simultaneous Multi-Projection Control</b>	Supported	-
<b>Data Storage Location</b>	PC and projector internal memory	Projector Internal Memory

When geometric distortion correction is enabled, the following functions cannot be used.

- KEYSTONE
- Corner Fit
- Pincushion

Applications can be downloaded from the link below. For details, please refer to the included manual.

👉 [FP-ZUH12000 Support Page](#)

# Installation Overview

- ▼ Installation and Storage Guidelines
- ▼ Spacing
- ▼ Height Adjustment
- ▼ Ceiling Mount Installation Precautions

## Installation and Storage Guidelines

Do not install or store the unit in the following locations:

- Locations subject to vibration or shock: Areas where vibration from the power supply is transmitted, or inside vehicles or vessels, etc. Such conditions may damage internal components and cause malfunction.
- Near high-voltage power lines or a power supply: These areas may be susceptible to electromagnetic interference.
- Locations with strong magnetic fields: Strong magnetic fields may cause a malfunction.
- Outdoors or in humid or dusty locations: In areas with oil smoke, steam, or corrosive gas, the cabinet may deform or crack, metal parts may corrode, or a malfunction may occur.
- Near the seaside: Exposure to corrosive salt air may result in damage or product malfunction, including the risk of the product falling.
- Near air conditioner vents: Direct exposure to hot or cold air may cause screen flickering.
- Near lighting equipment (such as studio lamps): Sudden changes in temperature may shorten the lifespan of the light source or cause unit deformation or malfunction.
- Near high-OUTPUT laser equipment: If laser light enters the projection lens, it may cause a malfunction of the DLP chip.

### Caution

If used in a dusty environment, the internal airflow system responsible for cooling and exhaust may become clogged, leading to a reduction in BRIGHT. or damage. Regular maintenance is required to prevent such issues.

### Caution

- Please do not install this unit in an enclosed space.
- "In the event that it must be installed in an enclosed space, please ensure that appropriate air conditioning or ventilation equipment is provided."

- "Insufficient ventilation may cause heat to accumulate, potentially leading to the shutdown of the device."
- "When fixing this unit to the ceiling or wall, please ensure that the mounting screws and power cord do not come into contact with any metal parts inside the wall or ceiling." Contact with metal parts may cause electric shock.
- "Please note that we cannot assume responsibility for any damage to the product caused by improper installation, even during the warranty period."
- If you decide to stop using the product, it is recommended that it be properly removed and disposed of.

## Spacing

"When installing the projector, choose a location where the vents will be a safe distance from walls or other obstructions." When installing units one above another using shelves or similar structures, leave a clearance of at least approximately 10 cm between the units and the shelves.

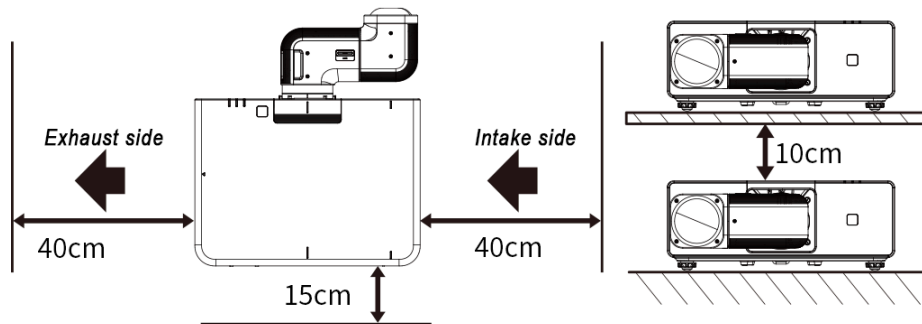

When using projectors side by side, provide installation clearance suitable for the ambient temperature (Ambient Temp). You will also need to ensure that warm air from the exhaust vent does not enter any of the projectors' intake vents.

Ambient temperature	Installation clearance
$\leq 33\text{ }^{\circ}\text{C}$	$\geq 0.8\text{ m}$
$\leq 34\text{ }^{\circ}\text{C}$	$\geq 1.0\text{ m}$
$\leq 39\text{ }^{\circ}\text{C}$	$\geq 2.0\text{ m}$

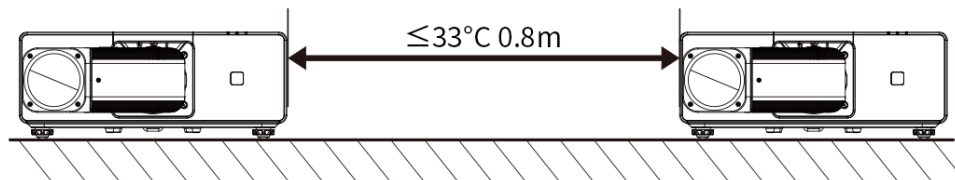

### ⚠ Caution

- Do not obstruct the vents. The build-up of heat inside the projector could cause fire.

- After startup, the image may shift by a few pixels until the Lens temperature is stabilized by the laser light source. Check again after 30 minutes to 1 hour. Also, do not adjust (readjust) geometric distortion correction or blending until it stabilizes.
- "If the projector is installed in a location where heat builds up, the image may become unstable." Make sure that the installation meets the conditions described above.

#### Note

Supports 360-degree omnidirectional installation.

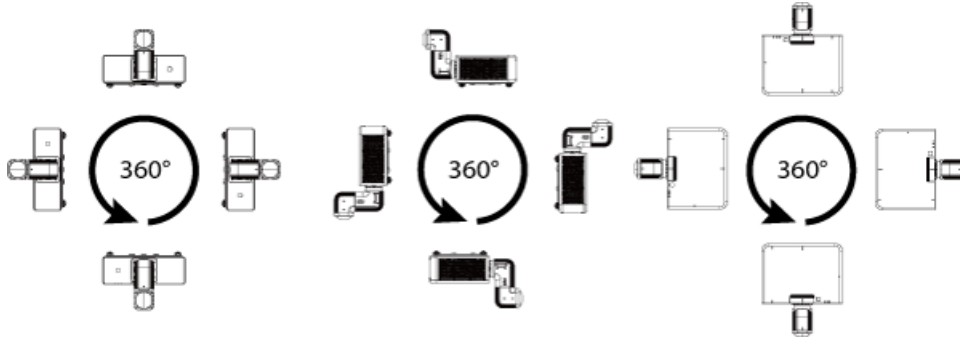

## Height Adjustment

Adjust the height using the adjustable feet. (Approx. 1.9 cm)

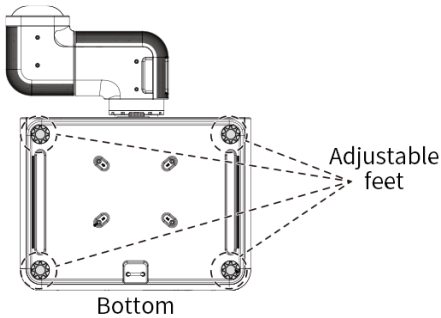

## Ceiling Mount Installation Precautions

- "When suspending the projector from the ceiling, be sure to use the specified ceiling mount"
- "When installing the projector, attach the drop-prevention kit included with the ceiling mount". Refer to your dealer if you require a drop-prevention kit.
- Ceiling installations should be performed only by qualified technicians.
- See the ceiling mount installation instructions for details.

## Ceiling Mount Screw Specifications

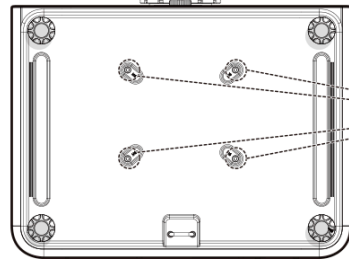
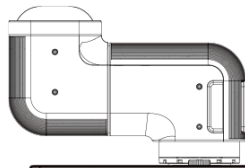

Bottom

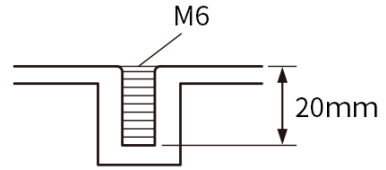

Screw tightening torque:  $4.0 \pm 0.5 \text{ N}\cdot\text{m}$



# Projection status adjustment

Press the “lens adjustment button” on the control panel or remote control to perform the main projection adjustments (Lens Shift, Focus, and Zoom) when installing the projector.

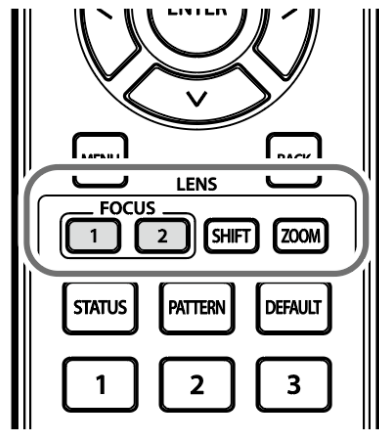

Remote control

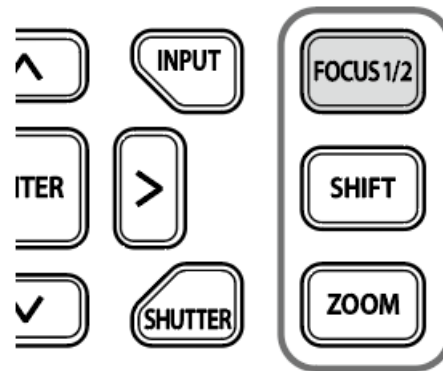

Main unit

- ▼ [Lens Shift Adjustment](#)
- ▼ [Focus Adjustment](#)
- ▼ [Zoom Adjustment](#)
- ▼ [Installation Method Adjustment](#)

## Lens Shift Adjustment

Adjusts the projected image position by shifting the lens optical axis (Lens Shift).

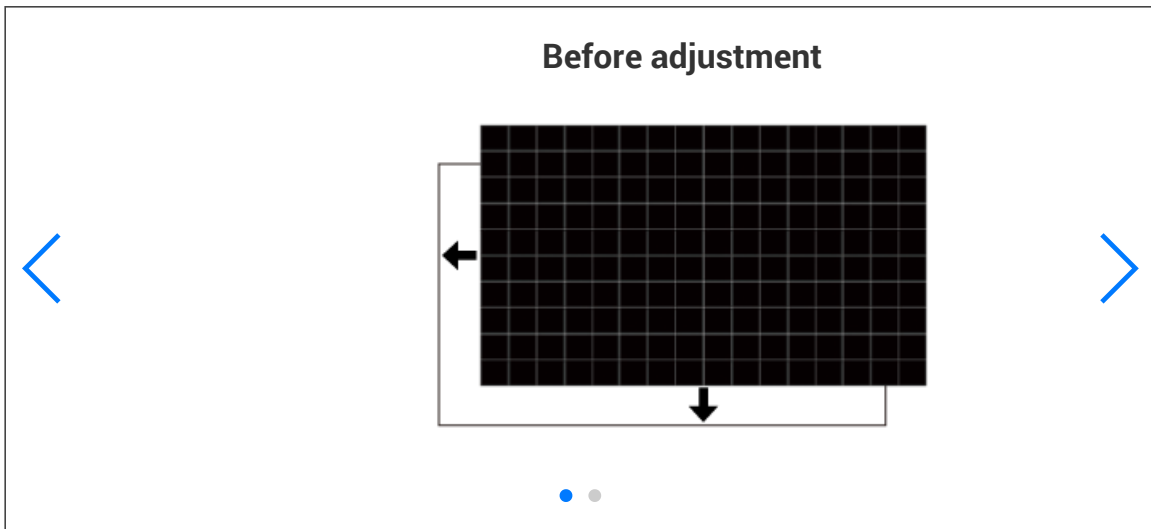

**7** **Remote control** : Press the **SHIFT** button.

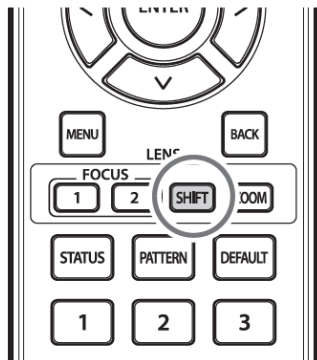

Remote control

**Projector** : Press the **SHIFT** button on the main unit control panel.

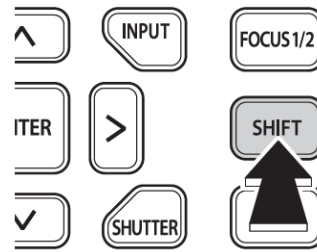

Main unit

**2** Adjust the position of the projected image using the selector (up/down/left/right) buttons.

**Note**

The values shown in % are reference values for the shift position.

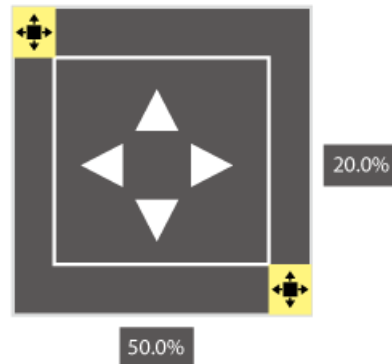

**3** Press the **BACK** button to exit.

**Note**

- Zoom adjustment can also be performed from the menu.

- Press and hold the SHIFT button on the remote control for 3 seconds to display the calibration confirmation screen. When calibration is complete, the shift position returns to the Home Position.
- After adjusting the shift, the focus may be slightly out of alignment. Readjust the focus as necessary.

## Focus adjustment

Adjust the focus of the projected image. Display Test Pattern 1.

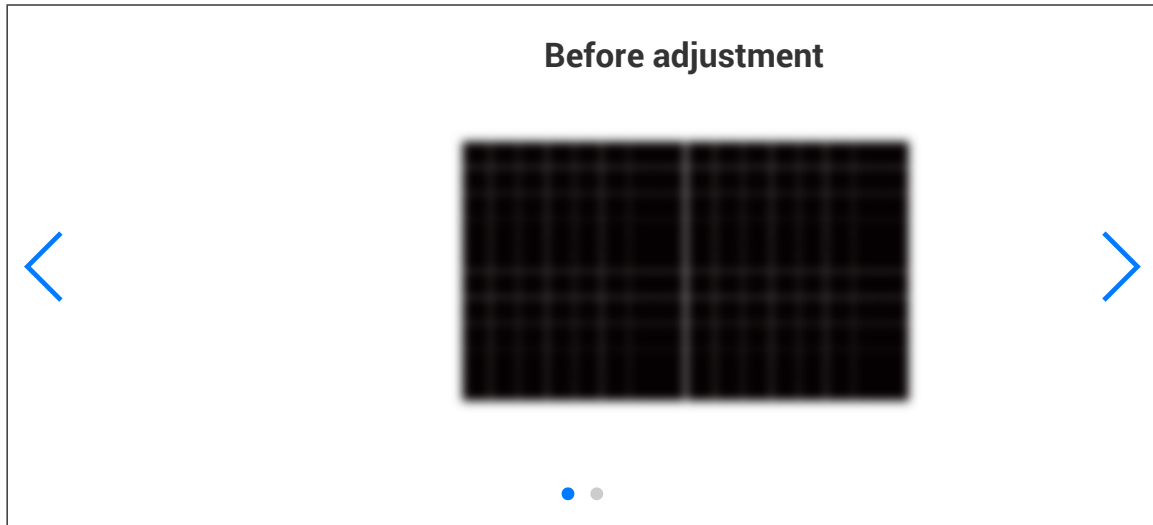

**1** : Use the “**FOCUS1**” and “**FOCUS2**” buttons on the remote control.

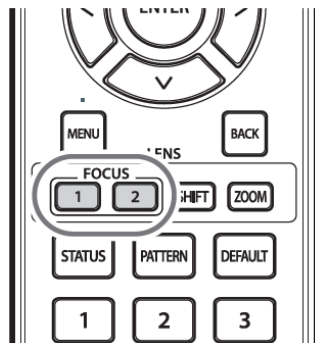

Remote control

: Use the “**FOCUS1/2**” buttons on the main unit control panel.

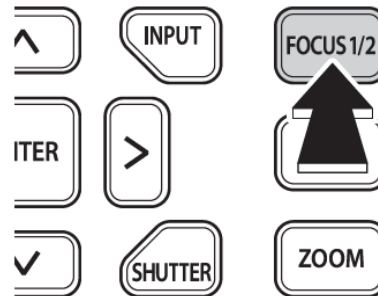

Main unit

**2** Adjust the focus using the selector (left/right) buttons.

The icon representing the focus being adjusted (1 or 2) will change.

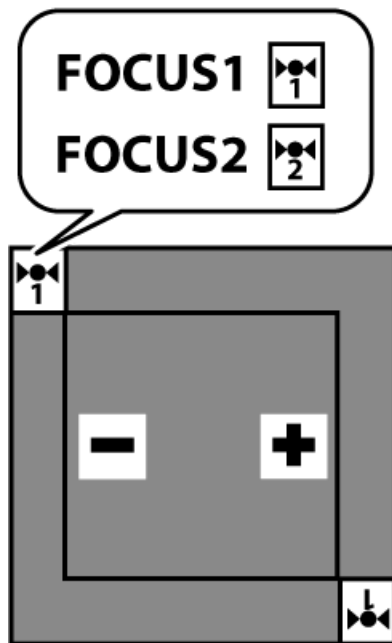

**3** When you have finished the adjustment, press the **BACK** button to exit.

 **Note**

Focus adjustment can also be performed from the menu.  
The **FP-ZL034** projection lens is adjusted using **FOCUS1** and **FOCUS2**.  
For the **FP-ZL050 / FP-ZL125** projection lens, use only **FOCUS1** for adjustment.

## Focus Adjustment

### ■ For the FP-ZL034

Adjust the focus using the **FOCUS1** and **FOCUS2** buttons on the remote control.

- **FOCUS1**: Adjusts the focus for the entire screen.
- **FOCUS2**: Adjusts the focus for the screen periphery.

Display Test Pattern 1 and adjust using the following procedure.

1. Use the **FOCUS1** button to focus the entire screen (①).  
Focus on the image at the "nearest position" between the lens and the screen.
2. Use the **FOCUS2** button to focus the periphery (②).  
Focus on the image at the "farthest position" between the lens and the screen.
3. Repeat Step ① to adjust overall focus using the **FOCUS1** button.
4. If you cannot achieve focus, repeat steps 1 through 3 to adjust the focus.

**Note**

If adjusting by the above steps does not eliminate the focus difference around the screen, use the **FOCUS1** button to adjust the focus around the screen within a range where the center of the screen is not heavily blurred.

When Lens Shift is at the Home Position

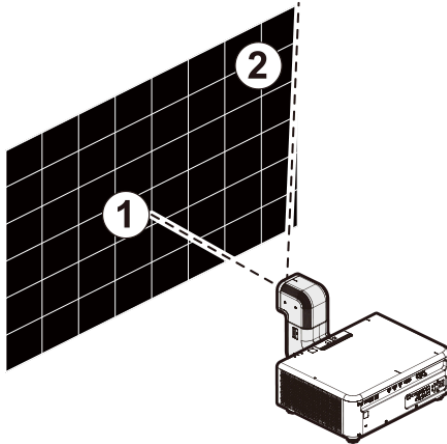

When Lens Shift is in the V (vertical) shift position

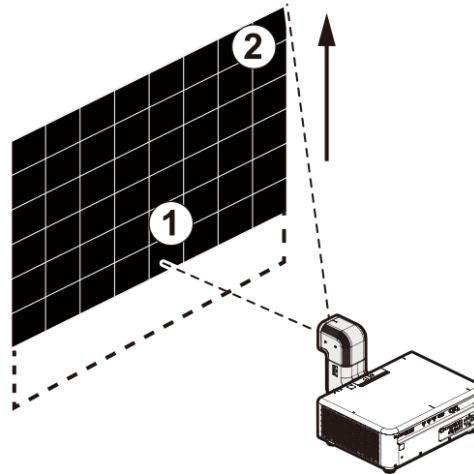

■ **For the FP-ZL050**

Before starting focus adjustment, rotate the floating ring (the part with the distance label) to align the lens distance indicator with the distance from the lens tip to the screen.

Use the **FOCUS1** button on the remote control to adjust the overall screen focus.

Distance from the lens tip to the screen

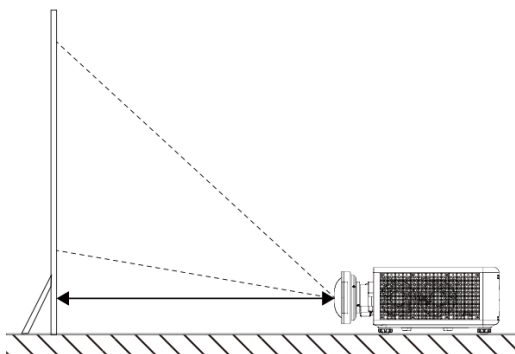

Align the distance indicator

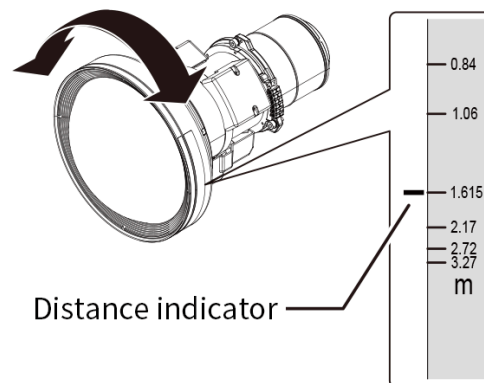

■ **For the FP-ZL125**

Use the **FOCUS1** button on the remote control to adjust the overall screen focus.

# Zoom Adjustment

Adjust the size of the projected image. Display Test Pattern 1.

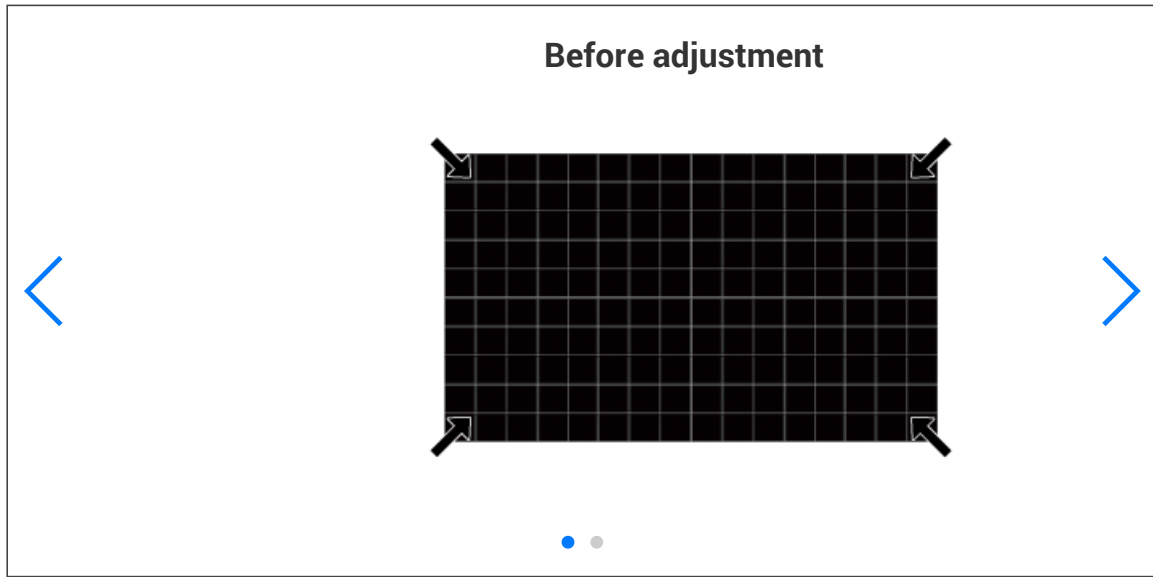

**1** : Press the **ZOOM** button.

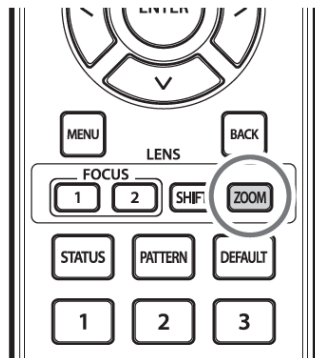

Remote control

: Press the **ZOOM** button on the main unit control panel.

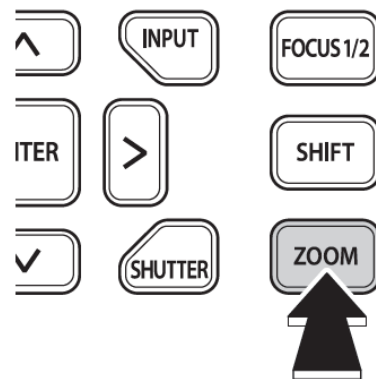

Main unit

**2** Use the left/right selector buttons to adjust the size of the projected image.

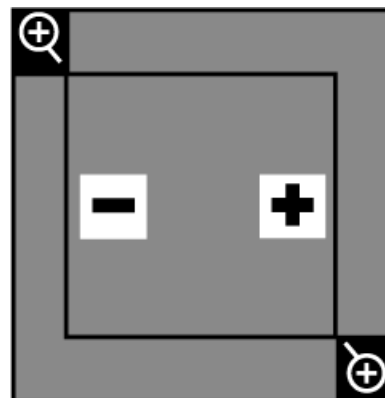

**3** Press the **BACK** button to exit.

 **Note**

- Zoom adjustment can also be performed from the menu.
- Focus may shift slightly after zoom adjustment. Readjust the focus as necessary.

## Installation Method Adjustment

Set the installation method that matches the installation status of the projector and screen.

Select **Front Table**, **Rear Table**, **Front Ceiling**, or **Front Ceiling** from **Projector Position** in the **display** menu ( **Projector Position**).

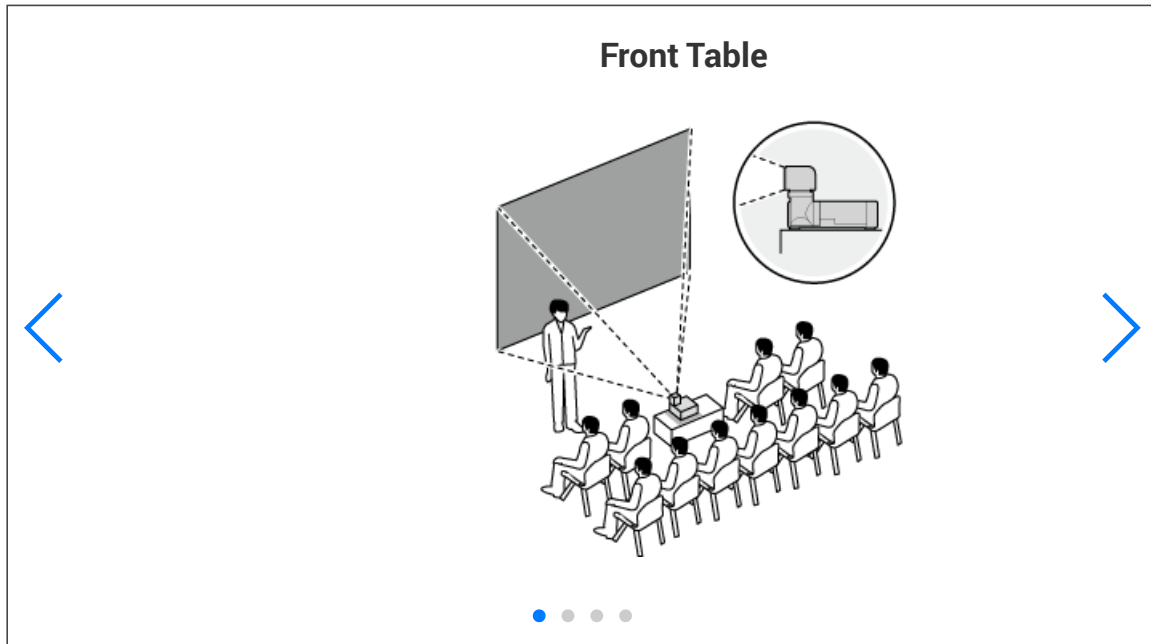

# Connecting to Other Devices



- ▼ [Wired Remote Control Connection](#)
- ▼ [Connecting to HDBaseT-Compatible Transmission Devices \(Commercially Available\)](#)
- ▼ [Connecting to LAN-Compatible Devices](#)
- ▼ [Connecting to HDMI-Compatible Devices](#)
- ▼ [Connecting to Audio Equipment](#)
- ▼ [Connecting to the RS-232C Terminal \(Serial Port\)](#)

## Wired Remote Control Connection

Connect the remote output terminal of the remote control to the remote input terminal of the main unit using a commercially available 3.5mm stereo mini-plug cable.

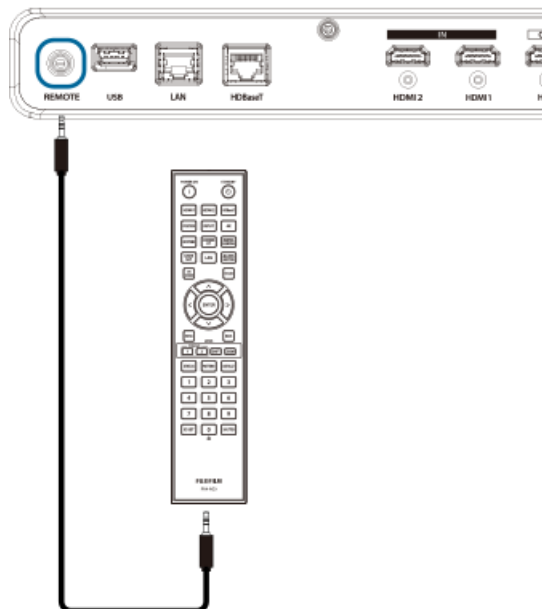

**⚠ Caution**

- Operation is not guaranteed in all Connection environments.

- When the remote output terminal is used, infrared signals are not emitted from the remote control.
- The Remote Receiver on the main unit remains On.  
To turn it Off, set it to Off in  [system setup: basic/remote receiver](#).

## Connecting to HDBaseT-Compatible Transmission Devices (Commercially Available)

When connecting to a commercially available HDBaseT-compatible transmission device, connect to the HDBaseT terminal.



### connection diagram

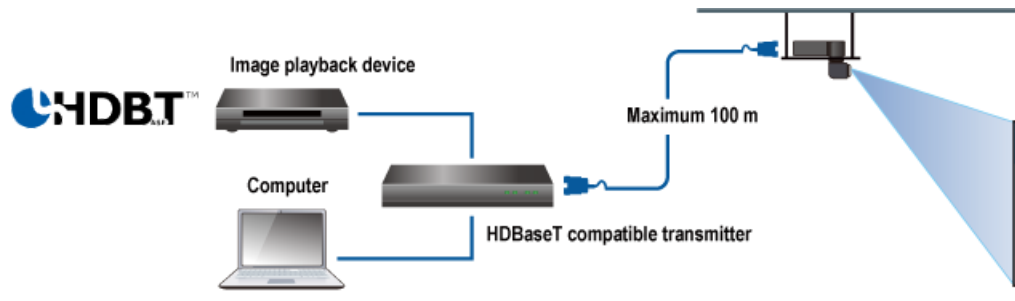

#### Note

- By setting Control Channel to HDBaseT in system setup: advanced LAN settings, LAN communications using the HDBaseT terminal are possible.

#### Caution

- Use a shielded STP cable of category 5e or higher for the Cat cable.
- The maximum transmission distance possible with a Cat cable is approximately 100 m.
- The HDBaseT terminal on this unit supports transmission devices compatible with serial communication and IR.  
To Enable IR via HDBaseT, set HDBaseT to On in  [system setup: basic/remote receiver](#).
- This unit is not guaranteed to operate with all commercially available HDBaseT-compatible transmission devices or in all connection environments.

## Connecting to LAN-Compatible Devices

When connecting to a LAN-compatible device, use a commercially available LAN cable to connect to the LAN terminal.



## connection diagram

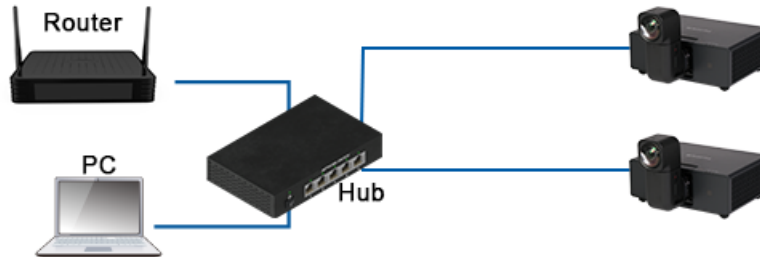

### ⚠ Caution

- The LAN terminal will be disabled if the Control Channel is set to HDBaseT in system setup: advanced LAN settings.
- This product cannot be connected directly to the communication lines of telecommunications carriers (mobile communications companies, fixed-line communications companies, internet service providers, etc.). When connecting this product to the internet, be sure to connect via a router or similar device.

## Connecting to HDMI-compatible devices

When connecting to an HDMI-compatible device, use the HDMI terminal.



### 📄 Note

- The HDMI OUT terminal can be switched between HDMI1/HDMI 2 in the **OUTPUT Setup** of the  input menu.

### ⚠ Caution

- When inputting or outputting 18Gbps transmission video such as 3840×2160 60p 4:2:2, please use a compatible HDMI cable.

# Connecting to the RS-232C Terminal (Serial Port)

When controlling this unit via RS-232C, connect to the RS-232C terminal.

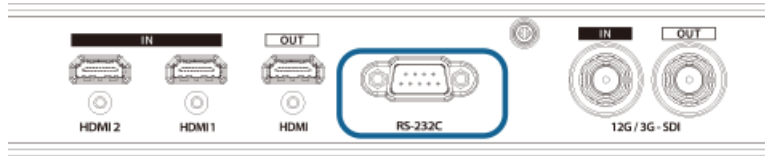

## Pin Assignment

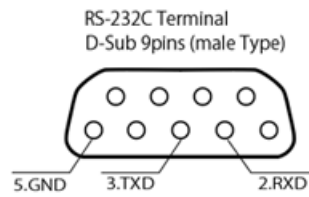

### RS232 Crossover Cable

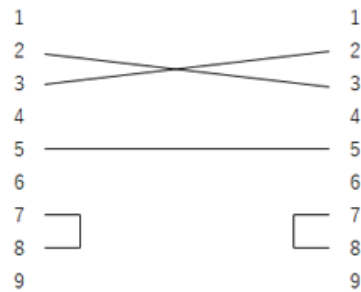

#### Note

- Use a commercially available crossover cable to connect to a PC or other device.

# Menu List

The projector menus are organized as shown below.

- ▼ DISPLAY
- ▼ PICTURE
- ▼ SOURCE
- ▼ SYSTEM SETUP : Basic
- ▼ SYSTEM SETUP : Advanced
- ▼ STATUS

## DISPLAY

MENU	Settings (Bold indicates the default settings)
<b>Lens Settings</b>	Lens Shift: —
	Lens Shift Settings: Shift Aea ( <b>Limited</b> / Full), Home Position ( <b>No</b> / Yes), Calibration ( <b>No</b> / Yes)
	Lens Shift Memory: Select Memory (Memory 1 to Memory 5), Load, Save, Clear, All Clear ( <b>Cancel</b> / Reset)
	Lens Motor Lock: Lock / <b>Unlock</b>
	Focus 1: —
	Focus 2: —
	Zoom: —
<b>TEST PATTERN</b>	<b>Off</b> / 1 / 2 / 3 / 4 / 5 / 6 / 7 / 8 / 9 / 10 / 11 / 12 / 13 / 14 / 15 / 16
<b>Projector Position</b>	<b>Front Table</b> / Rear Table / Rear Ceiling / Front Ceiling
<b>Aspect Ratio</b>	<b>Auto</b> / Real / 4:3 / 16:10 / 16:9 / 21:9
<b>Digital Zoom</b>	Proportional: On / <b>Off</b>
	Horizontal: 50.00%~ <b>100.00%</b> ~400.00%

	Vertical: 50.00%~ <b>100.00%</b> ~400.00%
	Digital Shift: Horizontal (0.00~ <b>50.00</b> ~100.00) / Vertical (0.00~ <b>50.00</b> ~100.00)
	Reset: <b>Cancel</b> / Reset
<b>Raster Position</b>	Horizontal: -1000~ <b>0</b> ~1000 (The upper/lower limit depends on signal or aspect ratio)
	Vertical: -600 to <b>0</b> to 600 (The upper/lower limit depends on signal or aspect ratio)
	Reset: <b>Cancel</b> / Reset
<b>Blanking</b>	TOP: <b>0</b> to 600 pixels
	Bottom: <b>0</b> to 600 pixels
	left: <b>0</b> to 1000 pixels
	Right: <b>0</b> to 1000 pixels
<b>Warping &amp; Blending</b>	Warping & Blending settings: <b>Off</b> / On / Application
	Grid Points: <b>2x2</b> / 3x3 / 5x5 / 9x9 / 17x17
	Warp Inner: On / <b>Off</b>
	Warp Sharpness: 0~ <b>19</b>
	Grid Color: <b>White</b> / Red / Green / Blue / Magenta / Cyan
	Grid Background: Black / <b>Transparent</b>
	Edge Blending Setup: Blend Width, overlap grid count ( <b>4</b> / 6 / 8 / 10 / 12), Gamma (1.8~ <b>2.2</b> ~2.4)
	Memory: Select Memory (Memory 1~Memory 5), Load, Save, Clear, All Clear (Cancel / <b>Reset</b> )
Reset: <b>Cancel</b> / Reset	
<b>Keystone</b>	Vertical: -60~ <b>0</b> ~60
	Horizontal: -60~ <b>0</b> ~60
<b>Corner Fit</b>	Top Left: Vertical: <b>0</b> ~80 / Horizontal: <b>0</b> ~ 120
	Top Right: Vertical: <b>0</b> ~ 80 / Horizontal: <b>0</b> ~ 120
	Bottom Left: Vertical: <b>0</b> ~ 80 / Horizontal: <b>0</b> ~ 120
	Bottom Right: Vertical: <b>0</b> ~ 80 / Horizontal: <b>0</b> ~ 120
<b>Pincushion</b>	H: 0~ <b>50</b> ~100

# PICTURE

MENU	Settings (Bold indicates the default settings)
<b>Picture Mode</b>	<b>Bright</b> / Standard[PROVIA] / Vivid[Velvia] / Cinema[ETERNA] / CLASSIC CHROME / CLASSIC Neg. / Multi-Projection[sRGB] / High Speed / HDR
<b>Brightness</b>	0 – <b>50</b> – 100
<b>Contrast</b>	-50 – <b>0</b> – 50
<b>TINT</b>	-50 – <b>0</b> – 50
<b>Saturation</b>	-50 – <b>0</b> – 50
<b>Gamma</b>	1.6 – <b>2.2</b> – 3.3
<b>Sharpness</b>	1 – <b>8</b> – 15
<b>Color Temperature</b>	3200K / 4200K / 5200K / 6200K / 6500K / <b>Default</b> / 8200K / 9300K
<b>Color Temperature Fine Tuning</b>	R / G / B gain: 0 – <b>100</b> – 200
	R / G / B offset: -50 – <b>0</b> – 50
<b>7colors Tuning</b>	When colors are Red/Green/Blue/Cyan/Magenta/Yellow <ul style="list-style-type: none"> <li>• Hue: 0–254</li> <li>• Saturation: 0–254</li> <li>• Gain: 0–254</li> </ul>
	When color is White <ul style="list-style-type: none"> <li>• Red Gain: 0–254</li> <li>• Green Gain: 0–254</li> <li>• Blue Gain: 0–254</li> <li>• White Peaking: 0~100</li> </ul>
<b>Dynamic Contrast</b>	DynamicBlack™: On / <b>Off</b>
	Speed: <b>1</b> to 255
	Level: 50 to <b>100%</b> (1% increments)
	Extreme Black: On / <b>Off</b>
	Light Out Timer: <b>0s</b> to 20s (1s increments)
	Light Out Signal Level: <b>1</b> to 255
	Lights on Threshold: <b>0</b> to 127

Reset: **Cancel** / Reset

## SOURCE

MENU	Settings (Bold indicates the default settings)
<b>Input</b>	<b>HDMI 1</b> / HDMI 2 / HDBaseT / 12G-SDI
<b>Output</b>	<b>HDMI 1</b> / HDMI 2
<b>Color Space Conversion</b>	<b>Auto</b> / RGB(0-255) / RGB(16-235) / YUV / REC709
<b>HDMI 1 Equalizer</b>	<b>Auto</b> / 1 / 2 / 3 / 4 / 5 / 6 / 7
<b>HDMI 2 Equalizer</b>	<b>Auto</b> / 1 / 2 / 3 / 4 / 5 / 6 / 7
<b>Backup Input Settings</b>	Auto Switch: On / <b>Off</b>
	Current Signal: HDMI 1 / HDMI 2 / HDBaseT(DISPLAY only)
	First Input: <b>HDMI 1</b> / HDMI 2 / HDBaseT
	Second Input: HDMI 1 / <b>HDMI 2</b> / HDBaseT
	Input Info. Current Signal, Backup Input Status, Backup Input Change, First Input (Resolution, vertical refresh, horizontal refresh, Color Space, HDR), Second Input (Resolution, vertical refresh, horizontal refresh, Color Space, HDR) (DISPLAY only)
<b>EDID Settings</b>	HDMI 1: <b>2.0</b> / 1.4 / Custom
	HDMI 2: <b>2.0</b> / 1.4 / Custom
	HDBaseT: <b>2.0</b> / 1.4 / Custom
<b>HDR</b>	<b>Auto</b> / Off

## SYSTEM SETUP : Basic

MENU	Settings (Bold indicates the default settings)
<b>Language</b>	24 LANGUAGE
<b>Menu Settings</b>	Menu Display Time: 5 sec / 10 sec / 20 sec / 30 sec / <b>Always</b>
	Menu Location: <b>Center</b> / Bottom Left / Bottom Right / Top Left / Top Right

	Reminder Message: <b>On</b> / Off
	Menu Transparency: <b>0</b> – 90
<b>Background Color</b>	<b>FUJIFILM(Blue)</b> / FUJIFILM(White) / FUJIFILM(Black) / Black / Blue / Custom
<b>Remote receiver</b>	Front: <b>On</b> / Off
	Top: <b>On</b> / Off
	Rear: <b>On</b> / Off
	HDBaseT: On / <b>Off</b>
<b>Projector ID Setting</b>	Enable: On / <b>Off</b>
	Projector ID: <b>00</b> – 99
<b>Panel Key Lock</b>	On / <b>Off</b>
<b>Backlight Preferences</b>	Panel Key: On / Off / <b>5 sec</b> / 10 sec / 20 sec / 30 sec
	Indicator: <b>On</b> / Off / Warning Error Only
<b>Security Settings</b>	<b>new password</b> / Change Password: Enter Security Code (4 digits)
	Power On Lock: On / <b>Off</b>
<b>4K Settings</b>	<b>On</b> / Off
<b>High Altitude Mode</b>	On / <b>Off</b>
<b>Reset Settings</b>	Display Settings: <b>Cancel</b> / Reset
	Picture Settings: <b>Cancel</b> / Reset
	BASIC Settings: <b>Cancel</b> / Reset
	ADVANCED Settings: <b>Cancel</b> / Reset
	Initialization: <b>Cancel</b> / Reset

## SYSTEM SETUP : Advanced

MENU	Settings (Bold indicates the default settings)
<b>Light Source Mode</b>	<b>Normal</b> / Eco
<b>Light Output Settings</b>	Light Output Setting: 10%~ <b>100%</b> (1%/step)
	Brightness Compensation: On / <b>Off</b>

<b>Shutter Setting</b>	Fade-In: <b>Off</b> / 0.5 s / 1 s / 1.5 s / 2 s / 2.5 s / 3 s / 3.5 s / 4 s / 4.5 s / 5 sec
	Fade-Out: <b>Off</b> / 0.5 s / 1 s / 1.5 s / 2 s / 2.5 s / 3 s / 3.5 s / 4 s / 4.5 s / 5 sec
	Startup: On / <b>Off</b>
<b>Operation Settings</b>	Direct Power On: On / <b>Off</b>
	Signal Power On: On / <b>Off</b>
	Auto Power Off: <b>0</b> to 180 m (5 m / step)
	Sleep Timer: <b>0.0</b> to 16.0 Hour (0.5 Hour / step)
<b>Standby Mode</b>	Standby / <b>Communication</b>
<b>Date and Time Settings</b>	Clock Mode: <b>Manual</b> / NTP
	Date: [YYYY/MM/DD]
	Time: [HH:MM]
	Daylight Saving Time: On / <b>Off</b>
	NTP Server IP Address: [xxx/xxx/xxx/xxx]
	Time Zone: UTC+14:00 to <b>UTC+00:00</b> to UTC-12:00
	Update Interval: <b>Hourly</b> / Daily
	Apply: <b>Yes</b> / No
<b>Schedule Settings</b>	Schedule Enable: On / <b>Off</b>
	Daily / Sunday / Monday / Tuesday / Wednesday / Thursday / Friday / Saturday: (Off / Schedule Enable (Off / <b>On</b> )), Event 01 to Event 16: (Time / Function / Event / Reset), Copy Events To: (Monday / Tuesday / Wednesday / Thursday / Friday / Saturday / Sunday), Reset the Day ( <b>Cancel</b> / Reset)
	Reset: <b>Cancel</b> / Reset
<b>LAN Settings</b>	Status: Connection / Disconnected (DISPLAY only)
	MAC Address: [XX:XX:XX:XX:XX:XX] (DISPLAY only)
	Control Channel: <b>LAN</b> / HDBaseT
	IPv4 Settings: DHCP (On / <b>Off</b> ), Projector IP Address ([xxx/xxx/xxx/xxx]), Subnet Mask ([xxx/xxx/xxx/xxx]), Default Gateway: ([xxx/xxx/xxx/xxx]), Primary DNS: ([xxx/xxx/xxx/xxx]), Secondary DNS: ([xxx/xxx/xxx/xxx]), Apply

	IPv6 Settings: DHCP (On / <b>Off</b> ), Projector IP Address ([xxxx:xxxx:xxxx:xxxx:xxxx:xxxx]), Pefix (0–128), Default Gateway: ([xxxx:xxxx:xxxx:xxxx:xxxx:xxxx]), DNS: ([xxxx:xxxx:xxxx:xxxx:xxxx:xxxx]), Apply
<b>LAN Control</b>	Crestron Connected V2: On / <b>Off</b>
	Extron IP LINK: On / <b>Off</b>
	PJLink: <b>On</b> / Off
	AMX Device Discovery: On / <b>Off</b>
	Telnet: <b>On</b> / Off
	HTTP: <b>On</b> / Off
<b>Serial Setting</b>	9600 / 19200 / 38400 / 57600 / <b>115200</b>
<b>User Settings</b>	Select Memory: Memory 1–Memory 5
	Load -
	Save -
	Clear -
	All Clear (Cancel / <b>Reset</b> )
<b>filter settings</b>	filter usage time: XXhr (DISPLAY only)
	filter usage reminder limit: 4000/3500/3000/2500/2000/1500/ <b>1000</b> Hour
	reset filter usage hours: <b>Cancel</b> / Reset

## STATUS

MENU	Settings (Bold indicates the default settings)
<b>Summary</b>	Current System Status
<b>System</b>	Current System Status (DISPLAY only), Model Name / lens model name, Serial Number, STANDBY MODE, picture mode, 4K Setting, Light Source Mode, Light Source Usage Total Hours, Total Projector Hours, Lens Motor Lock, filter installation, filter usage time
<b>System temperature/fan information</b>	System temperature, DMD board temperature, ambient temperature, phosphor wheel temperature, BLD1 temperature, BLD2 temperature, BLD3 temperature, BLD4 temperature, BLD5 temperature, BLD6 temperature, fan 1 temperature, fan 2 temperature, fan 3 temperature, fan 4

	temperature, fan 5 temperature, fan 8 temperature, fan 9 temperature, fan 10 temperature, fan 11 temperature (DISPLAY only)
<b>Communication</b>	"Projector ID, Network Status, Control Channel, MAC Address, IPv4 Settings, IPv6 Settings (read-only)"
<b>Signal</b>	Current Input Signal, Resolution, vertical refresh, horizontal refresh, pixel clock, Color Space (DISPLAY only)
<b>Backup Input Status</b>	Auto Switch: On/Off, first input signal, second input signal (DISPLAY only)
<b>firmware version</b>	"Main Version, F-MCU Version, A-MCU Version, Scaler Version, LAN Version, Formatter Version, and HDBaseT Version (read-only)"

---

# Using the Menu

To display the menu, press the MENU button on the main unit control panel or remote control.

- 1 The menu are displayed when you press the MENU button on the control panel or remote control.

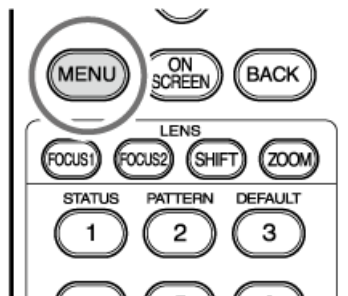

Remote control

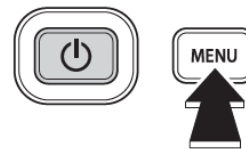

Control panel

- 2 Use the selector (left/right) button to select the desired menu.

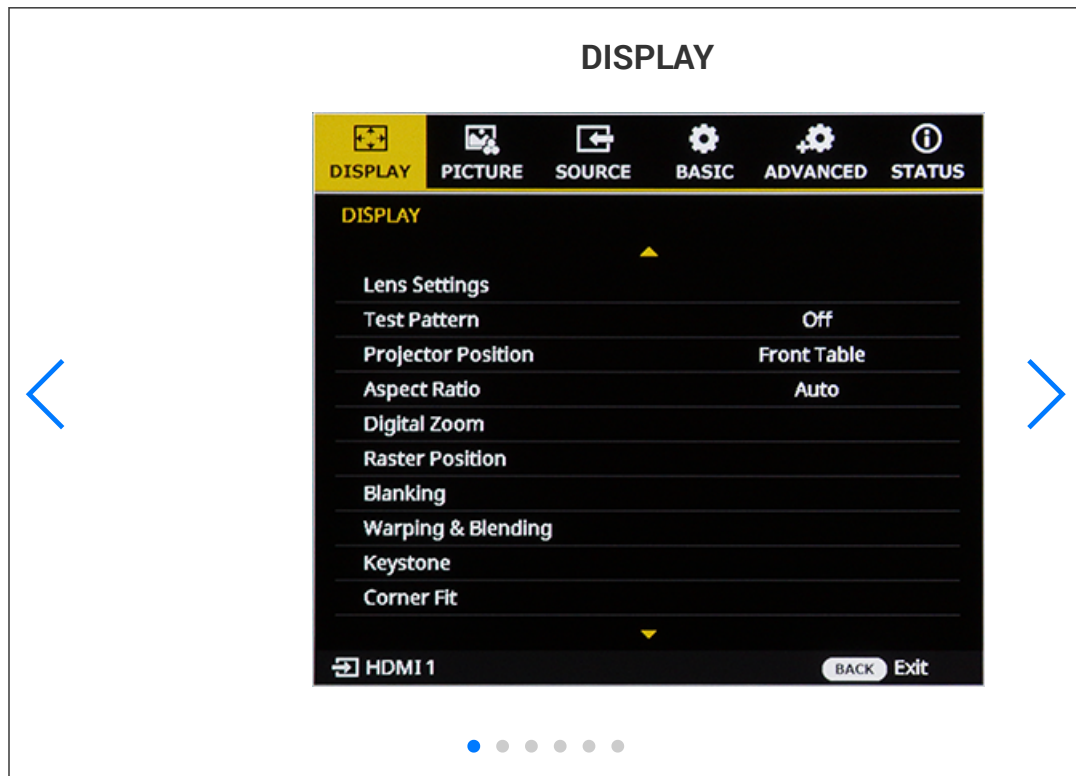

- 3 Use the selector (up/down) button to select a menu item.

---

**4** Use the selector (left/right) button to choose a setting value.

 **Note**

For menus that display "ENTER", press the **ENTER** button to open the settings menu and then configure the settings.

---

**5** Press the BACK button to Exit.

---

# DISPLAY

Configure settings related to the projector DISPLAY.

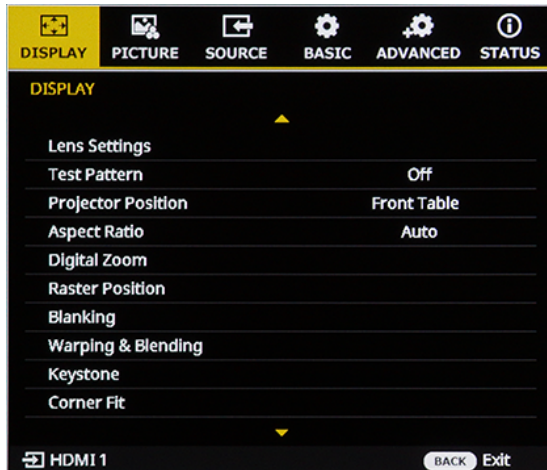

- ▼ Lens Settings
- ▼ TEST PATTERN
- ▼ Projector Position
- ▼ Aspect Ratio
- ▼ Digital Zoom
- ▼ Raster Position
- ▼ Blanking
- ▼ Warping & Blending
- ▼ KEYSTONE
- ▼ Corner Fit
- ▼ Pincushion

## Lens Settings

Configure settings related to the Lens.

Select the desired Lens Settings item and press the **ENTER** button to display the settings screen.

Item	Description
<b>Lens Shift</b>	Adjusts the projected image position by shifting the lens optical axis (Lens Shift).
<b>Lens shift settings</b>	Configure settings related to Lens Shift.
<b>Lens Shift Memory</b>	Save the Lens Shift Location.
<b>Lens Motor Lock</b>	When set to On, Lens Shift, Focus 1, Focus 2, and Zoom operations are disabled.
<b>Focus 1</b>	Adjust overall screen focus for the projected PICTURE.
<b>Focus 2</b>	Adjust focus at the screen periphery for the projected PICTURE.
<b>ZOOM</b>	Adjust the size of the projected image.

## Lens Shift

Press the **ENTER** button to display the Lens Shift adjustment screen, and use the arrow (up/down/left/right) buttons to adjust the projected image position.

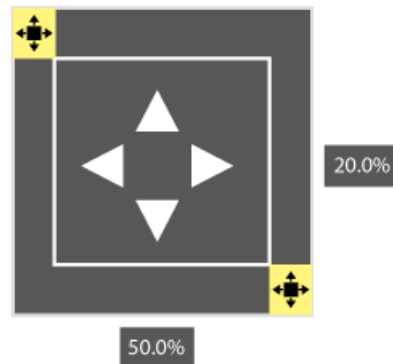

## Lens shift settings

Configure settings related to Lens Shift.

Press the **ENTER** button to display the submenu, and select the desired setting item.

### ■ Shift area

Select the Lens Shift Shift Area.

Setup	
Limited	Full

- **Limited:** Limit: Shifts the lens within the angle of full image visibility

- ① Center Location
- ② No image cropping when Lens Shift is moved to the Bottom Left

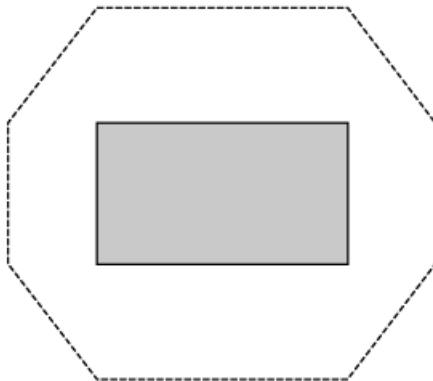

①

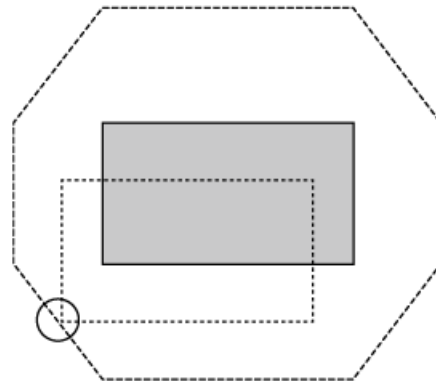

②

- **Full:** Shifts the Lens Shift Area to its maximum width.

- ① Center Location
- ② IMAGE is cropped when Lens Shift is moved to the Bottom Left

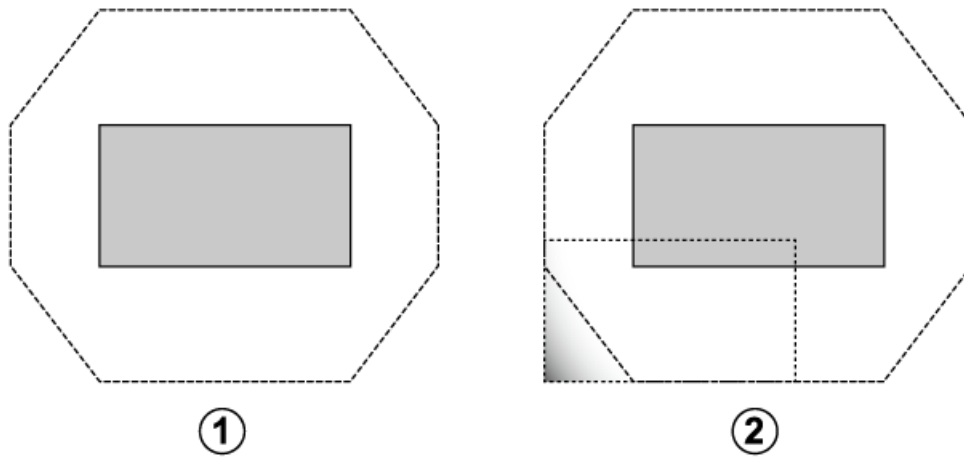

## ■ Home Position

Return the lens to the home position.

Press the ENTER button to display a confirmation screen for returning the lens to the home position.

Press OK to start lens shift. Do not perform other operations until the message displayed while the Lens is moving disappears.

## ■ Calibration

Perform lens calibration. When calibration is complete, a message appears prompting you to clear all lens shift memories.

## Lens Shift Memory

---

Save up to five Lens Shift Location settings.

Press ENTER to display options and then select the desired item.

1. Select **Select Memory** and press ENTER. Select the desired memory from **Memory 1** through **Memory 5** as needed.
2. Select any of the following items:
  - **Load**: Moves the lens to the Lens Shift position saved in the selected Memory.
  - **Save**: Saves the current Lens Shift position to the selected Memory.
  - **Clear**: Clears the contents of the selected Memory.
3. Selecting **All Clear** will clear the contents of all memories.

### Note

- Calibration can also be performed by pressing and holding the SHIFT button on the remote control for 3 seconds or more.
- To ensure accurate data recording, perform Calibration when using Lens Shift Memory for the first time.

## Lens Motor Lock

---

Lock or unlock lens motor.

Setup	Description
Lock	Locks operations for Lens Shift, Focus 1, Focus 2, and Zoom.
Unlock	Enables Lens Shift, Focus 1, Focus 2, and Zoom operations.

## Focus 1 / Focus 2

Adjust focus.

Press ENTER to display the focus dialog and use the selector (left or right ) to adjust focus.

- FOCUS1: Adjusts the optical axis center of the screen.
- FOCUS2: Adjusts the screen periphery.

Depending on the lens type, adjustments may be made using FOCUS1 only For details, please refer to "[Projection status adjustment](#)" and "[Focus adjustment](#)."

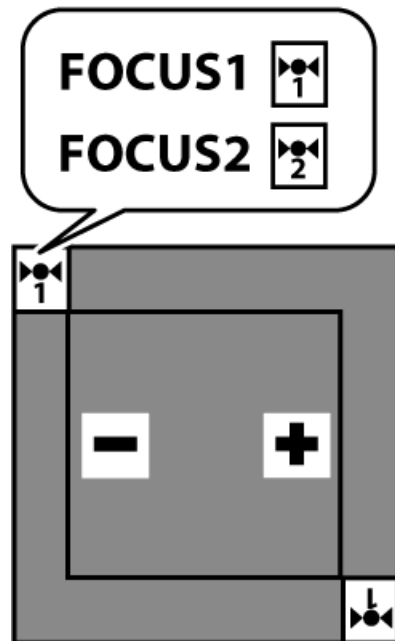

## ZOOM

Adjust the size of the projected image.

"Press ENTER to display the zoom dialog and use the selector (up, down, left, and right) to adjust the size of the projected image."

Select "-" to decrease the projected IMAGE size and "+" to increase it.

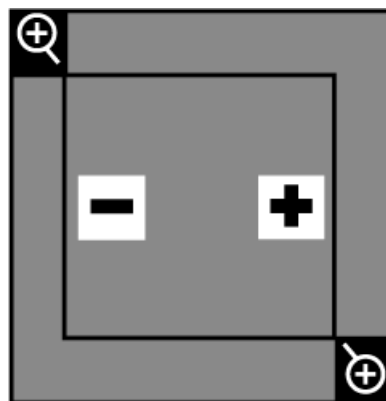

**TEST PATTERN**

Choose a grid or other test pattern for display during installation.

Setup																
Off	1	2	3	4	5	6	7	8	9	10	11	12	13	14	15	16

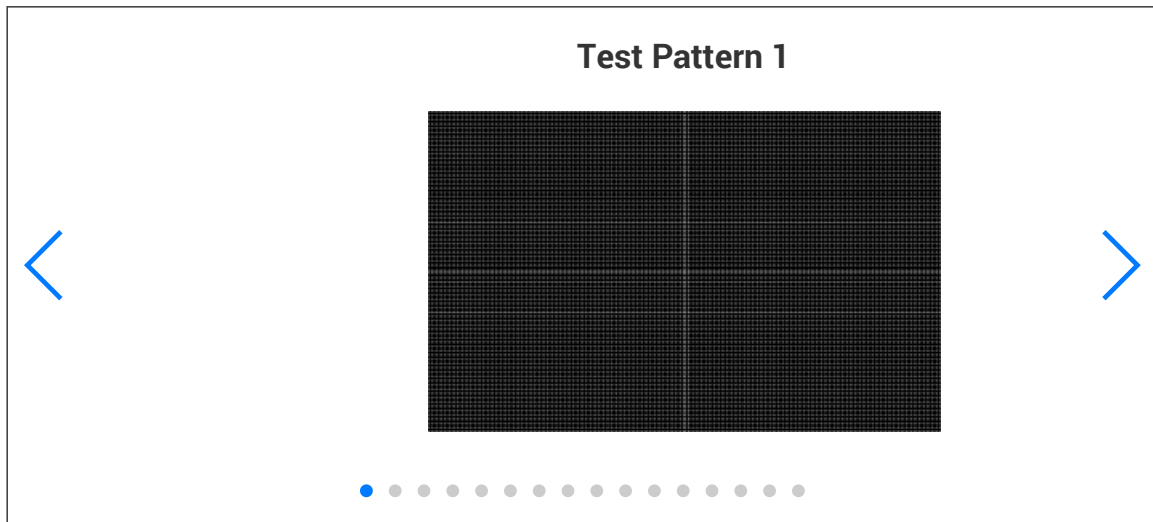

 **Note**

To temporarily hide the menu screen while a Test Pattern is displayed, press the ON SCREEN button on the remote control. Press the ON SCREEN button again to display the menu.

## Projector Position

Select the projection position according to the installation status of the projector.

Setup			
Front Table	Rear Table	Rear Ceiling	Front Ceiling

- **Front Table:** Choose if the projector is placed on a table in front of the screen.

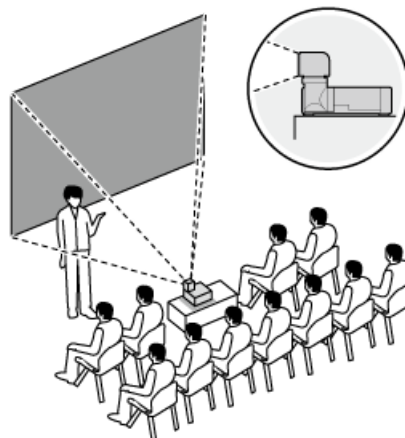

- **Rear Table:** Choose if the projector is placed on a table behind the screen.

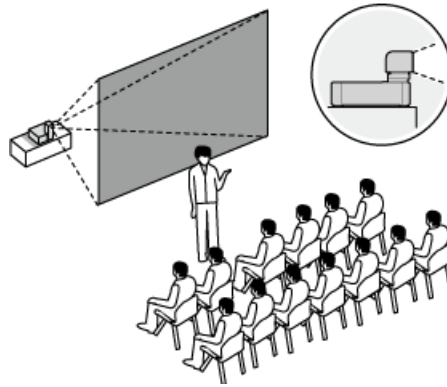

- **Rear Ceiling:** Select when the projector is suspended from the ceiling to project from behind the screen.

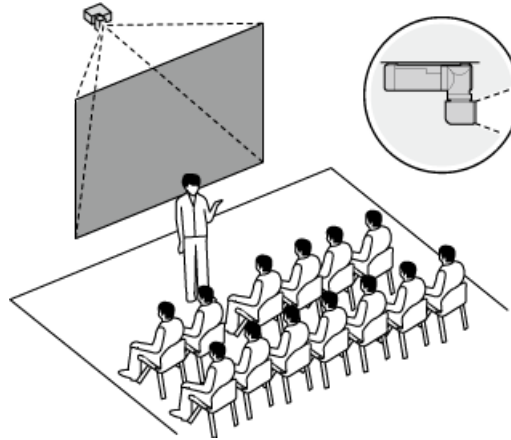

- **Front Ceiling:** Select when the projector is suspended from the ceiling to project from the front of the screen.

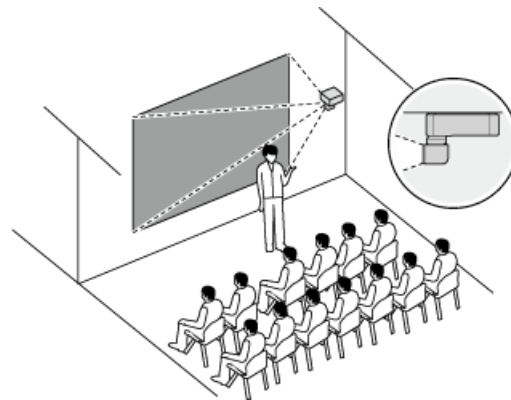

## Aspect Ratio

Position the beam according to the projector's location.

Setup					
Auto	Real	4:3	16:10	16:9	21:9

 **Note**

The setting for each input is stored separately.

## Digital Zoom

Zoom the projected image in using digital zoom.

Highlight **digital zoom** in the **DISPLAY** menu and press ENTER to show the options.

Item	Description
<b>Proportional</b>	Resize the projected image proportionally.
<b>Horizontal</b>	Adjusts the horizontal magnification of the projected image.
<b>Vertical</b>	Adjusts the vertical magnification of the projected image.
<b>Digital Shift</b>	Shift the image digitally
<b>Reset</b>	Reset digital zoom settings to the default values.

### Proportional

Set On to enable resizing the projected image proportionally or set Off to disable this function.

Setup	
On	Off

### Horizontal

Adjusts the horizontal magnification of the projected image.

Setup
50.00%~ <b>100.00%</b> ~400.00%

### Vertical

Adjusts the vertical magnification of the projected image.

Setup
50.00%~ <b>100.00%</b> ~400.00%

### Digital Shift

Shift the projected image digitally by increasing the horizontal and vertical magnification.

Setup	
<b>Horizontal</b>	0.00~ <b>50.00</b> ~100.00
<b>Vertical</b>	0.00~ <b>50.00</b> ~100.00

## Reset

Reset digital zoom settings to the default values.

Setup	
<b>Cancel</b>	<b>Reset</b>

## Raster Position

Input images that do not fill the display can be positioned as desired within the screen.

Setup	
<b>Horizontal</b>	Moves the projected PICTURE left or right within an Area of -1000 to 1000 pixels.
<b>Vertical</b>	Moves the projected PICTURE TOP or Bottom within an Area of -600 to 600 pixels.
<b>Reset</b>	Choose Reset to restore the raster position to the default values. When the confirmation screen appears, select Reset again and then select Yes to Confirm.

For example, suppose a PICTURE with an ASPECT RATIO of 16:9 is displayed on a screen with an ASPECT RATIO of 16:10.

- ① The screen ASPECT RATIO is 16:10.
- ② The PICTURE ASPECT RATIO is 16:9.
- ③ Use the Vertical Raster Position to move the PICTURE in the Vertical Direction and adjust the DISPLAY area.

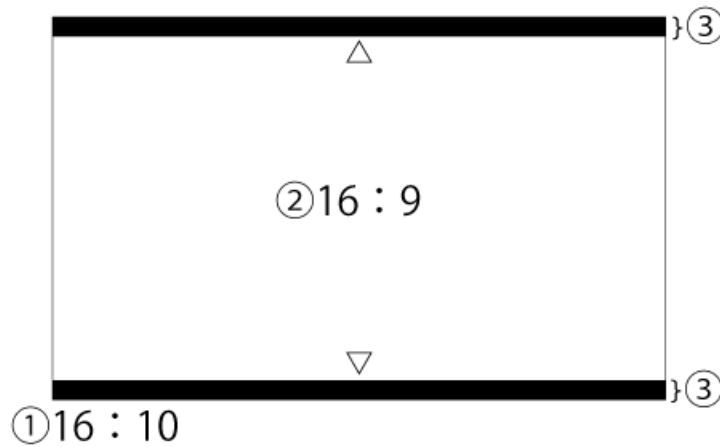

**Note**

The upper/lower limit depend on signal or aspect ratio.

## Blanking

The screen margins can be adjusted vertically by 600 pixels and horizontally 1000 pixels.

Item			
Top 600 pixels	Bottom 600 pixels	Left 1000 pixels	Right 1000 pixels

Press the selector up or down to highlight the desired margin and press left or right to adjust.

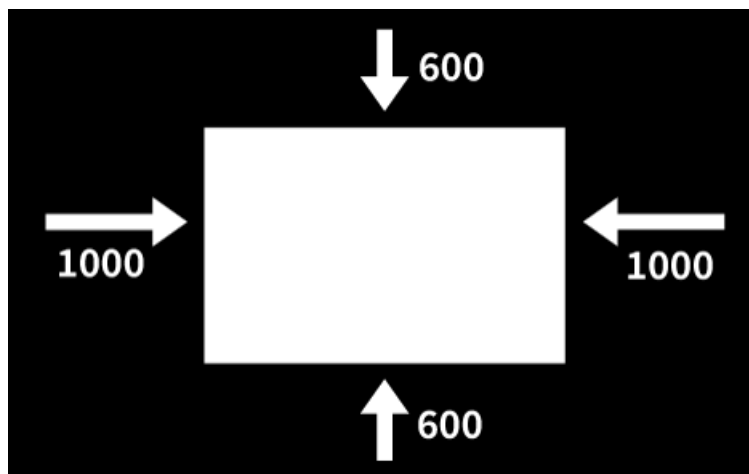

## Warping & Blending

To perform geometric distortion correction (warping) or to make the seams between images from multiple projectors less noticeable, use the geometric distortion correction and edge blending

function.

Press ENTER to display options and then select the desired item.

## Warping & Blending Settings

Setup	Description
Off	Disables the geometric distortion correction and edge blending function.
On	Enable the geometric distortion correction and edge blending function, and then configure the following: Grid Points, Warp Inner, Warp Sharpness, Grid Color, Grid Background, and Blend Settings.
Application	Use the Application to configure geometric distortion correction and Blend Settings.

- **Grid Points**

: Select the number of grid cells.

Item				
2x2	3x3	5x5	9x9	17x17

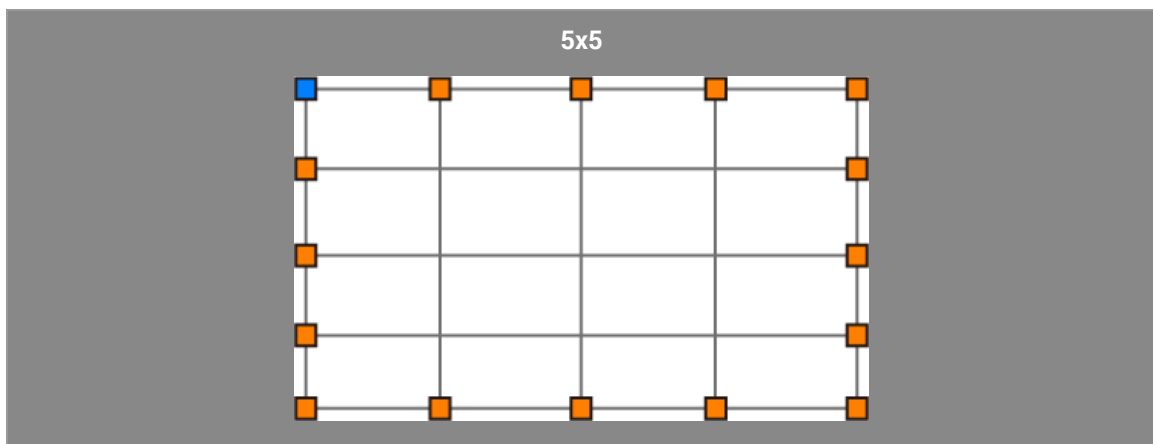

- **Warp Inner**

: Set to On to Add Point for adjustment inside the grid cells.

Item	
On	Off

1. "Press the selector up, down, left, or right to highlight the desired grid point that you want to modify."
2. Press the selector left or right to modify the desired grid point.

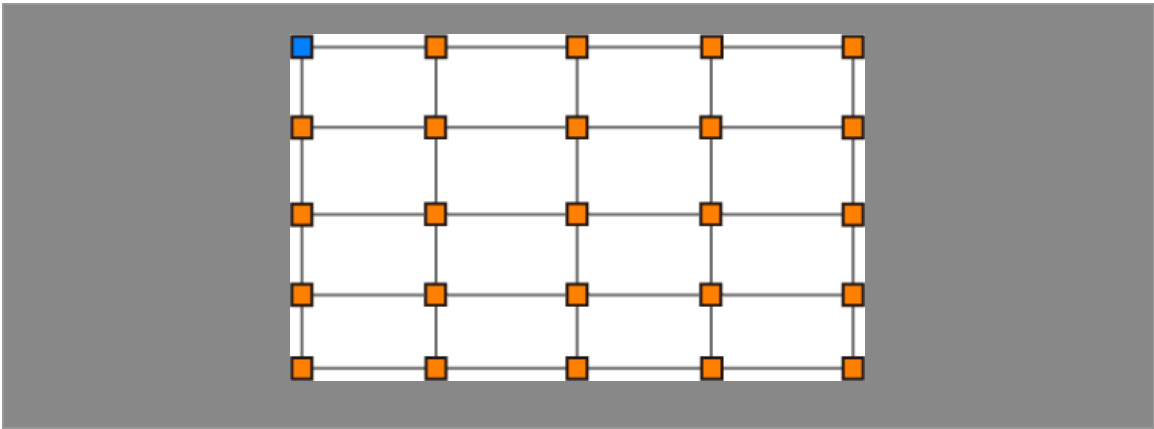

- **Warp Sharpness**

: Adjusts the sharpness during geometric distortion correction.

Item
0-19

- **Grid Color**

: Selects the grid color.

Item					
White	Red	Green	Blue	Magenta	Cyan

- **Grid Background**

: Selects the background color for the grid.

Item	
Black	Transparent

- **Edge Blend Settings**

: This function smooths the seams between images from multiple projectors to make them less noticeable.

Press ENTER to display options and then select the desired item.

- **Blend Width**: Sets the width of the blend area. "There are four options on blend width: up, down, left, and right." The adjusting unit is 4 pixels per step.

- **overlap grid count**: Select the number of grid lines per Blend Width to be displayed on the grid point screen from 4 / 6 / 8 / 10 / 12.

- **Gamma**: Specifies the gamma value for the overlapping areas within the range of 1.8-2.4.

- **Memory**

: Saves up to five geometric distortion correction & Edge Blend Settings.

Press ENTER to display options and then select the desired item.

1. Select **Select Memory** and press ENTER. Select the desired memory from **Memory 1** through **Memory 5** as needed.

2. Select any of the following items:

- **Load**: Loads the geometric distortion correction and edge blending settings from the selected memory.

- **Save**: Saves the geometric distortion correction and edge blending settings to the

selected memory.

- **Clear**: Clears the contents of the selected memory.

3. Selecting **All Clear** will clear the contents of all memories.

- **Reset**

: To reset geometric distortion correction & Blend Settings to the Default Value, press Enter and select **Reset** when the confirmation screen is displayed.

## Keystone

Unavailable when Geometric Distortion Correction & Blend Settings are set to On or Application.

Corrects trapezoidal distortion (keystone adjustment) that occurs when the image is not projected perpendicular to the Screen.

Press the **Enter** button to display the keystone correction screen, and use the selector (up/down/left/right) button to correct trapezoidal distortion.

Negative values reduce the size of the projected image while positive values increase it.

Axis	Range
Vertical (V)	-60 ~ 0 ~ 60
Horizontal (H)	-60 ~ 0 ~ 60



## Corner Fit

Unavailable when Geometric Distortion Correction & Blend Settings are set to On or Application.

Adjust the Four Corners of the PICTURE individually to ensure the image is free of distortion.

Item	Range
Top Left	Vertical: 0 ~ 80
	Horizontal: 0 ~ 120
Top Right	Vertical: 0 ~ 80

	Horizontal: <b>0</b> ~ 120
Bottom Left	Vertical: <b>0</b> ~ 80
	Horizontal: <b>0</b> ~ 120
Bottom Right	Vertical: <b>0</b> ~ 80
	Horizontal: <b>0</b> ~ 120

**1** Press the **ENTER** button to display the Corner Fit screen.

**2** Use the selector (up/down/left/right) button to select the area to be corrected, then press the **ENTER** button.

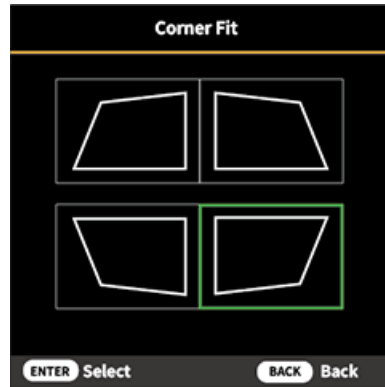

**3** Position the corner horizontally and vertically.



**4** Position the corner horizontally and vertically.

## Pincushion

Unavailable when Geometric Distortion Correction & Blend Settings are set to On or Application.

Adjusts images that have barrel distortion or pincushion distortion.

Item	Range
Horizontal	0~ <b>50</b> ~100

Vertical

0~50~100

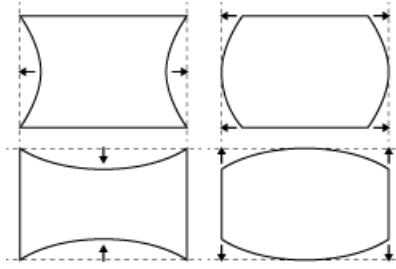

# PICTURE

Adjust the projected image.

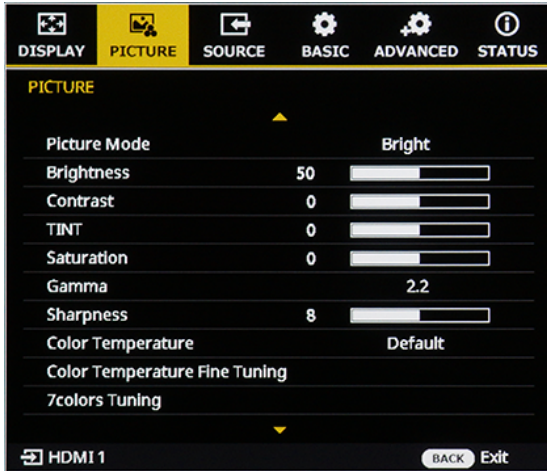

- ▼ Picture Mode
- ▼ Brightness
- ▼ Contrast
- ▼ TINT
- ▼ Saturation
- ▼ Gamma
- ▼ Sharpness
- ▼ Color Temperature
- ▼ Color Temperature Fine Tuning
- ▼ 7colors Tuning
- ▼ Dynamic Contrast

## Picture Mode

Select the picture mode.

Setup	Description
<b>Bright</b>	Ideal for use in bright environments.
<b>Standard [PROVIA]</b>	Suitable for a wide range of content with standard color reproduction and natural gradation.
<b>Vivid [Velvia]</b>	Projects high-contrast images with vibrant color reproduction.
<b>Cinema[ETERNA]</b>	Projects images with soft, subdued colors and rich shadow tones.
<b>CLASSIC CHROME</b>	Low saturation and high-contrast shadow gradation.
<b>CLASSIC Neg.</b>	Enhanced depth through hard tonality and distinct color tones in highlights and shadows, with suppressed saturation.
<b>Multi-Projection [sRGB]</b>	Compliant with the sRGB standard.
<b>High Speed</b>	Switches to High Speed mode when a 120/240 Hz signal is input.

<b>HDR</b>	Switches to HDR mode when an HDR (High Dynamic Range) signal is input.
------------	--

 **Note**

The projector automatically detects the Input Signal and switches to High Speed or HDR mode.

## Brightness

Adjust the brightness of the projected image.

<b>Setup</b>
0~50~100

## Contrast

Adjust the Contrast (the difference between bright and dark areas) of the PICTURE.

<b>Setup</b>
-50~0~50

## TINT

Adjust colors in the projected image. "The higher the value, the greener the image, the lower the value, the redder the image."

<b>Setup</b>
-50~0~50

## Saturation

Adjust the Saturation of the PICTURE. The "+" side makes colors deeper, and the "-" side makes colors lighter.

<b>Setup</b>
-50~0~50

## Gamma

Perform gamma adjustment for the PICTURE.

Setup
1.6~2.2~3.3

## Sharpness

Adjust the sharpness of outlines.

Setup
1~8~15

## Color Temperature

Adjusts the color temperature for the projected image.

Setup							
3200K	4200K	5200K	6200K	6500K	DEFAULT	8200K	9300K

## Color Temperature Fine Tuning

Allows for advanced adjustment of the set color temperature white balance.

Press the **ENTER** button to display the color temperature fine tuning screen, use the up and down selector buttons to select an item, and use the left and right buttons to adjust.

Item	Description
<b>R Gain</b>	Adjust the contrast of reds. Choose from values between 0 and 200. "The lower the value, the lower the contrast; the higher the value, the higher the contrast."
<b>G Gain</b>	Adjust the contrast of greens. Choose from values between 0 and 200. "The lower the value, the lower the contrast; the higher the value, the higher the contrast."
<b>B Gain</b>	Adjust the contrast of blues. Choose from values between 0 and 200. "The lower the value, the lower the contrast; the higher the value, the higher the contrast."

<b>R Offset</b>	Adjust the brightness of reds. Choose from values between -50 and 50. "Lower values reduce brightness, while higher values increase it"
<b>G Offset</b>	Adjust the brightness of greens. Choose from values between -50 and 50. "Lower values reduce brightness, while higher values increase it"
<b>B Offset</b>	Adjust the brightness of blues. Choose from values between -50 and 50. "Lower values reduce brightness, while higher values increase it"

## 7colors Tuning

"Adjust hue, gain, and saturation for each of seven color channels (R, G, B, C, M, Y and W)."

Press the **ENTER** button to display the 7colors Tuning screen, use the left/right selector button to choose a color, and adjust each item.

### "Red, Green, Blue, Cyan, Magenta, or Yellow Selected for Color"

Item	Range
<b>Hue</b>	0 ~ 254
<b>Gain</b>	0 ~ 254
<b>Saturation</b>	0 ~ 254

### White Selected for Color

Item	Setup
<b>R Gain</b>	0 ~ 254
<b>G Gain</b>	0 ~ 254
<b>B Gain</b>	0 ~ 254

### White Peaking

Adjust the brightness of whites.

Setup
0 ~ 100

# Dynamic Contrast

Configure the dynamic contrast to maximize the contrast of dark content.

Press **ENTER** to display options and then select the desired item.

## DynamicBlack™

When this Function is Enabled, the contrast ratio of the input image is Adjusted automatically. Improves the Black Level of dark scenes by optimizing the light source output.

Setup	Range
On	Enable <b>DynamicBlack™</b> and Adjust the correction speed and Brightness Level.
Off	Disable <b>DynamicBlack™</b> .

- **Speed**  
: Adjust the correction speed of the light source output. The value range is 1 to 255. Lower value makes the correction slower and less aggressive while a higher value results in the faster correction.
- **Level**  
: Adjust the light source when the Brightness Level of the input image falls below the Setup value. The value range is 50% to 100%. "The higher the value, the larger the range to adjust the light source."

## Extreme Black

Enabling this function reduces the light source output to a specified Level when a black image is detected.

Setup	Range
On	Enable <b>Extreme Black</b> and configure the Light Out Timer, Light Out Signal Level, and Lights on Threshold.
Off	Disable <b>Extreme Black</b> .

- **Light Out Timer**  
: Setup the amount of time until the light source output is lowered after a Black PICTURE is detected. The Setup range is from **0s to 20s**.
- **Light Out Signal Level**  
: Setup the Signal Level at which the light source output is lowered. The value range is **1 to 255**.
- **Lighting Threshold**  
: Setup the threshold to restore the light source output. The value range is **0 to 127**.

## Reset

Reset the **Dynamic Contrast** Setup to the Default Value.

Setup

Cancel

Reset

 **Note**

DynamicBlack™ and Extreme Black cannot be used at the same time.

---

# SOURCE

Configures settings related to input.

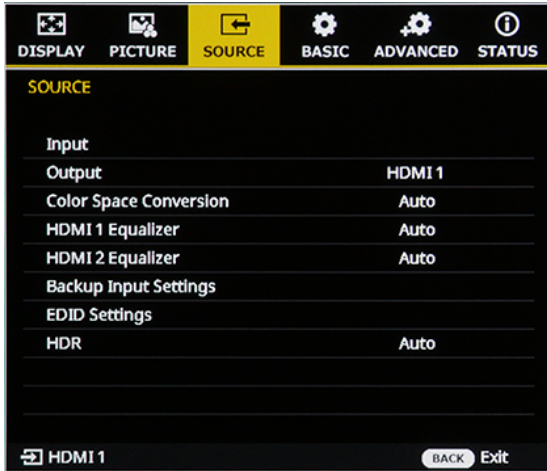

- ▼ input
- ▼ Output
- ▼ Color Space Conversion
- ▼ HDMI 1 Equalizer
- ▼ HDMI 2 Equalizer
- ▼ Backup Input Settings
- ▼ EDID Settings
- ▼ HDR

## Input

Choose an input source.

Setup			
HDMI1	HDMI 2	HDBaseT	12G-SDI

## Output

Choose an output source.

Setup	
HDMI1	HDMI 2

## Color Space Conversion

Choose the color space in which images are displayed.

Setup
-------

Auto	RGB(0-255)	RGB(16-235)	YUV	REC709
------	------------	-------------	-----	--------

## HDMI 1 / HDMI 2 Equalizer

Adjusts for stable signal transmission when using long HDMI cables. Adjust the settings according to your usage conditions.

Setup							
Auto	1	2	3	4	5	6	7

## Backup Input Settings

The projector can automatically switch to a backup Input Signal if the primary Input Signal becomes unavailable. (The PICTURE signals from both input ports must be identical.)

Press ENTER to display options and then select the desired item.

### Auto Switch

Enables or disables the input signal auto switch.

Setup	Description
On	Enables input signal auto switch.
Off	Disables input signal auto switch.

### Current Signal

Displays the Current Input Signal (view only).

### First Input / Second Input

Choose first and second input.

Setup		
HDMI1	HDMI 2	HDBaseT

### Input Info.:

Displays the Current Input Signal, Backup Input Status, backup input operation status, and input signal details.

The Backup Input Status allows you to identify whether Auto Switch is actually available.

## EDID Settings

Sets the EDID version supported by each input port.

Press ENTER to display options and then select the desired item.

### HDMI 1 / HDMI 2 / HDBaseT EDID Settings

Setup		
2.0	1.4	Custom

#### Note

When set to Custom, the factory default is the same as 2.0. To change the content, you must upload an EDID information file via the [web control function](#).

## HDR

Sets the HDR function.

Setup	Description
<b>Auto</b>	Automatically detect HDR signal.
Off	Turns the HDR function Off. When set to Off, the projector cannot display HDR signals.



# SYSTEM SETUP : Basic

Adjust basic system settings.

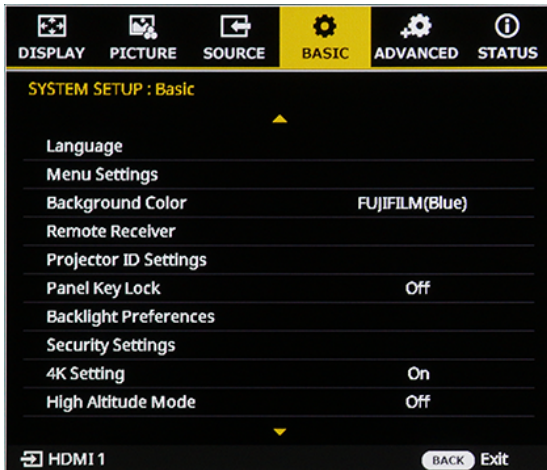

- ▼ Language
- ▼ Menu Settings
- ▼ Background Color
- ▼ Remote receiver
- ▼ Projector ID Setting
- ▼ Panel Key Lock
- ▼ Backlight Preferences
- ▼ Security Settings
- ▼ 4K Settings
- ▼ High Altitude Mode
- ▼ Reset Settings

## Language

Choose the language in which menus and other items are displayed.

Setup		
English	日本語	ไทย
Français	한국어	Norsk
Deutsch	Svenska	Bahasa Indonesia
Italiano	Nederlands	Tiếng Việt
Español	Türkçe	Čeština
Русский	Portuguese	Suomi
繁體中文	Polski	Ελληνικά
简体中文	Dansk	Magyar

# Menu Settings

Adjust menu display settings.

Press the **ENTER** button to select Menu Preferences.

## Menu Display Time

Choose how long the menus are displayed on the screen.

Setup				
5 sec	10 sec	20 sec	30 sec	Always

### Note

The operation screens for Lens Shift, Focus 1/2, and Zoom are always displayed for 30 s.

## Menu Position

Choose where the menus are displayed on the screen.

Setup				
Center	Top Left	Top Right	Bottom Right	Bottom Left

## Reminder Message

Select **On** to display alerts.

Setup	
On	Off

### Note

Selecting **Off** for **Reminder Message** disables the display of alarm alert messages.

HDMI 1



Checking For Signal

## Menu Transparency

Adjust the transparency of the menu.

Setup

## Background Color

Choose the menu background color.

Setup					
FUJIFILM(Blue)	FUJIFILM(White)	FUJIFILM(Black)	Black	Blue	Custom

### Note

When set to Custom, the factory default is Black. To use a custom background, you must upload a background image using the  [web control function](#).

## Remote receiver

Enables or disables the light receiver used by the remote control.

Press ENTER to display options and then select the desired item.

Setup	Description
Front	On / Off
Top	On / Off
Rear	On / Off
HDBaseT	On / Off

## Projector ID Setting

Choose an ID for each projector.

Press ENTER to display options and then select the desired item.

### Enable

Setup	Description
Off	Turn the projector ID off. "The projector can be controlled by from any remote, regardless of its ID."

On	Choose the projector ID. The remote control must be set to the same ID (refer to the  <a href="#">How to Set the ID Number</a> ).
----	--

## Projector ID

Choose the projector ID.

Setup
00~99

After completing the setup, press the Enter button to apply the changes.

## Panel Key Lock

Lock the controls on the body of the projector.

Setup	
On	Off

### Note

- "To release the control-panel lock, press the selector right for three seconds."

## Backlight Preferences

Configure the back light behavior and timeout setting for the panel keys and LED indicator. Press ENTER to display options and then select the desired item.

## Panel Key

Choose how long the backlight remains on when you press the control panel keys.

Setup					
On	Off	5 sec	10 sec	20 sec	30 sec

### Note

- Selecting **Off** for **Panel Key** disables the backlight function; selecting **On** keeps the control panel backlight lit until the projector is turned off.

## Indicator

Choose when to light on the LED indicator.

Setup		
On	Off	Warning Errors Only

## Security Settings

Adjust security settings.

Press the **ENTER** button to change the password.

### New Password

1. Press **ENTER** to set a new password.
2. Set a four-digit password using a combination of the numbers 0–9.
3. You must enter the password twice for confirmation. Press the **ENTER** button to confirm. The password set here must be entered when Power On Lock is set to On.

### Change Password

1. Press **ENTER** and change the password.
2. Enter the current password.
3. Set a new four-digit password using a combination of the numbers 0–9.
4. You must enter the password twice for confirmation. Press the **ENTER** button to continue.

#### Note

- Failure to provide the correct password for three times will prevent the projector being used or initialized. Be careful not to lose the Password. If the Password is lost, please consult your retailer.

### Power On Lock

When set to **On**, you will be prompted to enter the password set in **New/Change Password** immediately after turning on the Projector.

Setup	
On	Off

#### Note

Selecting **On** will display the screen to Input the Password.

## 4K Settings

Set to **On** to Enable 4K Setting, or **Off** to disable it.

Setup	
On	Off

## High Altitude Mode

When using the product at high altitudes (approx. 1,500 m/4,900 ft or higher), set **High Altitude Mode** to **On** to ensure the System Temperature is correctly Adjust. Failure to observe this precaution could shorten the life of the product's parts.

Setup	
On	Off

## Reset Settings

Restore all items in the selected menu to their factory default settings.

Press the ENTER button, select the menu to be reset, and then execute the reset.

Setup	Description
<b>Display Settings</b>	Resets the <b>display</b> menu to its factory default settings.
<b>Picture Settings</b>	Resets the <b>picture</b> menu to its factory default settings.
<b>BASIC Settings</b>	Restores the <b>system settings: basic</b> menu to its factory default settings.
<b>ADVANCED Settings</b>	Restores the <b>system settings: advanced</b> menu to its factory default settings.
<b>Initialize</b>	Resets all menu items (DISPLAY, PICTURE, SYSTEM SETUP : Basic, and SYSTEM SETUP : Advanced) to their Default Value. However, the following menus will not be Reset. <ul style="list-style-type: none"><li>• <b>DISPLAY &gt; Lens Settings</b></li><li>• <b>SYSTEM SETUP : Basic &gt; Security Settings</b></li><li>• <b>SYSTEM SETUP : Advanced &gt; Date and Time Settings</b></li></ul>

### Note

A confirmation screen will be displayed when you select a menu and press ENTER. Select Reset to restore the selected menu item to its Default Value.

# SYSTEM SETUP : Advanced

Adjust advanced system settings.

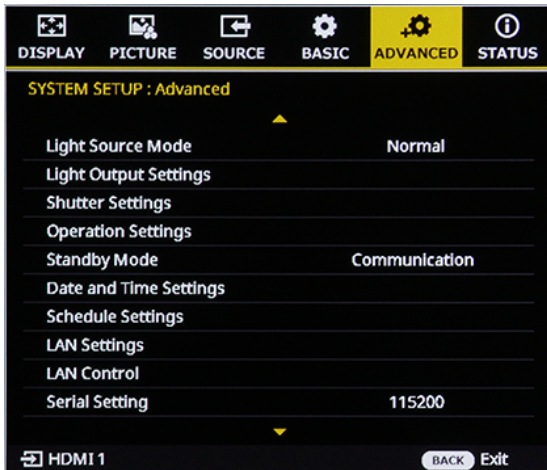

- ▼ Light Source Mode
- ▼ Light Output Settings
- ▼ Shutter Setting
- ▼ Operation Settings
- ▼ Standby Mode
- ▼ Date and Time Settings
- ▼ Schedule Settings
- ▼ LAN Settings
- ▼ LAN Control
- ▼ Serial Setting
- ▼ User Settings
- ▼ Filter Settings

## Light Source Mode

Choose a light-source brightness mode.

Setup	
Normal	Eco

## Light Output Settings

Press ENTER to display options and then select the desired item.

### Light Output Settings

Adjust Light Output Settings. This cannot be configured when Light Source Mode is set to Eco.

Setup	
10%~100%	

## Brightness Compensation

Select **On** to optimize the quality of the projected image for various ambient light conditions.

Setup	
On	Off

### Note

**Brightness Compensation** is available only when **Light Output Settings** is between **50% and 80%**.

## Shutter Setting

Configure settings related to the projector Shutter.

Press **ENTER** to display options and then select the desired item.

### Fade-In

Choose how long the picture takes to fade in after the shutter button is pressed to resume projection.

Setup										
Off	0.5 sec	1 sec	1.5 sec	2 sec	2.5 sec	3 sec	3.5 sec	4 sec	4.5 sec	5 sec

### Fade-Out

Choose how long the picture takes to fade out when the shutter button is pressed to suspend projection.

Setup										
Off	0.5 sec	1 sec	1.5 sec	2 sec	2.5 sec	3 sec	3.5 sec	4 sec	4.5 sec	5 sec

### Startup

Choose the shutter status when the projector is turned on.

Setup	
On	Off

# Operation Settings

Configure timers and other settings.

Press **ENTER** to display options and then select the desired item.

## Direct Power On

When set to **On**, the projector will turn on automatically (without pressing the power button) if the main power switch is on when power is supplied.

Setup	
On	Off

## Signal Power On

When set to **On**, the projector will turn on automatically if an Input Signal is detected while in Standby mode.

Setup	
On	Off

## Auto Power Off

"When there is no input signal for more than a certain period of time and the projector is not operated, it automatically goes into standby mode."

### Note

This function is not enabled when a built-in test pattern of this unit is projected.

Choose the length of time before the projector automatically enters standby.

Setup
0-180 m

## Sleep Timer

Choose the length of time before the projector automatically enters standby when the sleep timer is enabled.

Setup
0.0-16.0 Hours

## Standby Mode

---

Choose a standby mode.

Setup	
STANDBY	Communication

- **Standby:** While in standby, only power-on commands from the control panel, remote control, and serial port are available.
- **Communications:** While in standby, commands from the control panel, remote control, and serial port, as well as functions enabled via LAN Control, can be used.

## Date and Time Settings

Configure date and time settings.

Press **ENTER** to display options and then select the desired item.

## Clock Mode

---

Choose the clock mode.

Setup	Description
Manual	Manually enter the <b>date</b> and <b>time</b> .
NTP	Obtains Date and Time Settings via LAN. Configure <b>Daylight Saving Time</b> , <b>NTP Server IP Address</b> , <b>Time Zone</b> , and <b>Update Interval</b> settings.

### Note

To set **Clock Mode** to **NTP**, an NTP server must be available on the network to which the projector is connected.

## Date

---

Enter a value for the date in [MMDDYYYY] format.

## Time

---

Enter a value for the time in [HH:MM] format.

## Daylight Saving Time

---

Enable or disable daylight saving time.

Setup	
On	Off

## Time Zone

Choose an appropriate time zone for the network clock mode.

Setup
UTC+14:00 to <b>UTC+00:00</b> to UTC-12:00

## Update Interval

Choose the date and time update interval.

Setup	
Hourly	Daily

## Apply

Select **Yes** when the confirmation screen is displayed to save the Date and Time Settings.

Setup	
Yes	No

## Schedule Settings

Schedule various projector functions at the given date and time.

Press ENTER to display options and then select the desired item.

## Schedule Enable

Select **On** to enable the SCHEDULE.

Setup	
On	Off

Item							
Daily	Sunday	Monday	Tuesday	Wednesday	Thursday	Friday	Saturday

#### Note

Selecting **Daily** sets the SCHEDULE for every day of the week.

1. Choose a day of the week to display options for the selected day.
2. Set **Schedule Enable** to **On**.
3. Select an event from **Event 01 –Event 16** and configure the Advanced SCHEDULE settings.
  - a. Setup the event **time**.
  - b. Select a **Function**. Function options include **Power Settings**, **Input Source**, **Light Source Mode**, and **Shutter**. The Event will be disabled if set to **Off**. Then press ENTER.
  - c. Select the type of event: **Event [Power Settings] (Power On, Standby, standby (communication))**, **Event [Input Source] (HDMI 1, HDMI 2, HDBaseT)**, **Event [Light Source Mode] (Normal, Eco)**, or **Event [Shutter] (Shutter On, Shutter Off)**. Then, press the ENTER button.
  - d. To reset event settings to the Default Value, select **Reset** and then select **Reset** on the confirmation screen. When a confirmation message is displayed, select **Yes**.
4. To copy all event records for that day to another day of the week, select **Copy Events To** and choose the day of the week. When a confirmation message is displayed, select **Yes**.
5. To reset the event records for a day, select **Reset the Day** and then select **Reset** on the confirmation screen. When a confirmation message is displayed, select **Yes**.

## Reset

Restores **Schedule Settings** to the Default Value.

Setup	
Cancel	Reset

## LAN Settings

Adjust network settings.

Press ENTER to display options and then select the desired item.

## Status

View the projector's connection status (read-only).

## MAC Address

View the projector's MAC address (read-only).

## Control Channel

Select the LAN terminal to be used for Projector Control.

Setup	
LAN	HDBaseT

## IPv4 Settings

Configure IPv4 settings.

Item	Description
<b>DHCP</b>	Select <b>On</b> to use DHCP (Dynamic Host Configuration Protocol). When set to <b>Off</b> , the following items can be configured.
<b>Projector IP Address</b>	Set the IP address.
<b>Subnet Mask</b>	Enter a sub-net mask.
<b>Default Gateway</b>	Enter the default gateway address.
<b>Primary DNS</b>	Setup the Primary DNS Server address.
<b>Secondary DNS</b>	Setup the Secondary DNS Server address.
<b>Apply</b>	Press the ENTER button to apply the changes.

## IPv6 Settings

Configure the IPv6 Settings.

Item	Description
<b>DHCP</b>	Select <b>On</b> to use DHCP (Dynamic Host Configuration Protocol). When set to <b>Off</b> , the following items can be configured.
<b>Projector IP Address</b>	Set the IP address.
<b>Prefix</b>	Set the prefix.
<b>Default Gateway</b>	Enter the default gateway address.
<b>DNS</b>	Enter a DNS server address.
<b>Apply</b>	Press the ENTER button to apply the changes.

## LAN Control

Configure LAN control settings.

Item	Port Number	Description
<b>Crestron Connected® V2</b>	TCP/UDP 41794	Select <b>On</b> to control the projector using a Crestron controller and related software. To disable this function, select <b>Off</b> . Advanced settings are configured on the web control screen.
<b>Extron® IP LINK</b>	TCP 4023	Select <b>On</b> to control the projector using Extron IP LINK devices. To disable this function, select <b>Off</b> .
<b>PJLink™</b>	TCP/UDP 4352	Select <b>On</b> to control the projector using PJLink commands. To disable this function, select <b>Off</b> .
<b>AMX® Device Discovery</b>	UDP 9131	Select <b>On</b> to control the projector using an AMX device. To disable this function, select <b>Off</b> .
<b>Telnet</b>	TCP 3023	Select <b>On</b> to control the projector using RS232 commands over a Telnet connection. To disable this function, select <b>Off</b> .
<b>HTTP (web control)</b>	TCP 80	Select <b>On</b> to control the projector using a web browser. To disable this function, select <b>Off</b> .

## Serial Setting

Set the baud rate for serial port.

Setup				
9600	19200	38400	57600	<b>115200</b>

### Note

When performing serial communication via **HDBaseT™**, the baud rate is fixed at **115200**.

## User Settings

Save up to five customized settings.

Press ENTER to display options and then select the desired item.

1. Select **Select Memory** and press ENTER. Select the desired memory from **Memory 1** through **Memory 5** as needed.
2. Select any of the following items:
  - **Load**: Loads User Settings from the selected memory.

- **Save:** Saves User Settings to the selected memory.
  - **Clear:** Reset the settings of the selected memory record to the default values.
3. Selecting **All Clear** resets all memory records to their default values.

## Filter Settings

Setup	Description
<b>Filter Settings</b>	Manages the filter usage hours of the filter installed in the Projector. Press the ENTER button to display the Setup screen, then select the desired item.
<b>Filter Usage Time</b>	Displays the filter usage hours (display only).
<b>Filter Usage Reminder Limit</b>	Select the usage time at which the filter replacement message is displayed. Setup: 4000/3500/3000/2500/2000/1500/1000 Hours
<b>Reset Filter Usage Hours</b>	Resets the filter usage hours. Execute this function after replacing the filter.

# STATUS

Displays the current system status.

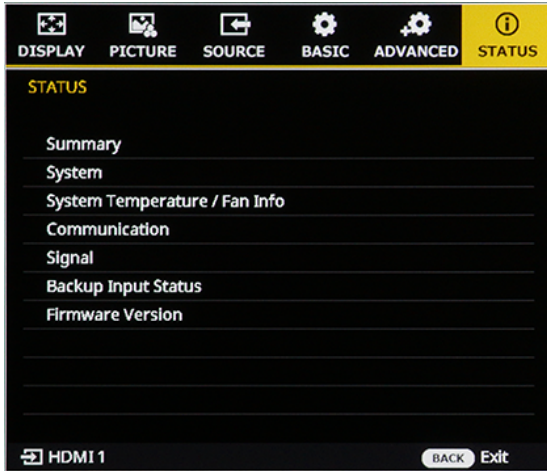

Item	Content
<b>Summary</b>	Displays the Current System Status, Model Name / lens model name, Serial Number, Current Input Signal, Resolution, horizontal and vertical refresh rate, picture mode, Projector IP Address, Light Source Usage Total Hours, Projector ID, Firmware Version, filter installation, and filter usage time.
<b>System</b>	Displays the Current System Status (display only), Model Name / lens model name, Serial Number, STANDBY MODE, picture mode, 4K Setting, Light Source Mode, Light Source Usage Total Hours, Total Projector Hours, Lens Motor Lock, filter installation, and filter usage time.
<b>System temperature/fan information</b>	Displays the System Temperature, fan speed, etc.
<b>Communication</b>	Displays the Projector ID, Network Status, Control Channel, MAC Address, IPv4 Settings (Projector IP Address, Subnet Mask, Default Gateway, primary and secondary DNS), and IPv6 Settings (Projector IP Address, Prefix, Default Gateway, DNS).
<b>Signal</b>	Displays the Current Input Signal, Resolution, vertical and horizontal refresh rate, pixel clock, and Color Space.
<b>Backup Input Status</b>	Displays the first and second input signal, their vertical and horizontal refresh rate, pixel clock, and Color Space.

<b>Firmware Version</b>	Displays the Main Version, F-MCU, A-MCU, scaler, LAN, Formatter, and HDBaseT versions.
-------------------------	--

---

# Main Specifications

- ▼ Main Unit Specifications
- ▼ Optional Lens Specifications

## Main Unit Specifications

<b>Model Name</b>		FP-ZUH12000		
<b>Panel</b>	<b>Size</b>	0.8 inches (aspect ratio 16:10)		
	<b>display system</b>	1-chip DLP® system		
	<b>pixel count</b>	2,304,000 pixels (1920 × 1200)		
<b>Lens</b>		OPTION Lens (sold separately)		
<b>Light source</b>		Laser diode		
<b>Brightness (ANSI lm *1)</b>		12,000 lm/12,400 lm (center)*2		
<b>light output half-life *3</b>		Approx. 20,000 hours		
<b>Contrast ratio *4</b>		25,000:1		
<b>Speaker</b>		-		
<b>Screen resolution</b>		4K 3840 × 2400 (When 4K mode is On)		
<b>Connection terminal</b>	<b>For video input</b>	<b>HDMI® 1</b>	Type A	Supports HDMI® 2.0 and HDCP 2.3
		<b>HDMI® 2</b>	Type A	Supports HDMI® 2.0 and HDCP 2.3
		<b>12G/3G-SDI</b>	BNC	Supports 12G/3G-SDI
		<b>HDBaseT™</b>	RJ-45	Supports HDBaseT™ 3.0
	<b>For Picture Output</b>	<b>HDMI®</b>	Type A	Supports HDMI® 2.0 and HDCP 2.3

		<b>12G/3G-SDI</b>	BNC	Supports 12G/3G-SDI
<b>For control</b>		<b>LAN</b>	RJ-45	For network connection (10Base-T/100Base-TX)
		<b>HDBaseT</b>	RJ-45	For projector control
		<b>RS-232C</b>	D-Sub 9-pin male	For projector control
<b>Remote input terminal</b>		<b>REMOTE</b>	3.5mm stereo mini jack	For remote control (wired)
<b>OTHER</b>		<b>USB</b>	Type A	DC 5V 2.0A (Maximum) power supply, for maintenance
<b>POWER</b>			AC 100–120V, AC 220–240V 50/60 Hz	
<b>Power consumption</b>	<b>Maximum</b>		900W	
	<b>Light Source Mode: Normal</b>		780W	
	<b>Light Source Mode: Eco Mode</b>		400W	
	<b>Standby</b>		Approx. 0.5W	
	<b>Network standby</b>		Approx. 8.0W	
<b>External dimensions (width × depth × height)</b>			535 × 396 × 189 (excluding adjustable feet and projections)	
<b>Weight</b>			Approx. 18.1 kg	
<b>Noise level<sup>*5</sup></b>	<b>Light source mode: normal</b>		Maximum 38dB	
	<b>Light source mode: eco mode</b>		Maximum 36 dB	
<b>Operating environment</b>	<b>Operating temperature</b>		0–40 °C	
	<b>Operating humidity</b>		10–85% (no condensation)	
	<b>Storage temperature</b>		–20–60 °C	
<b>Accessories</b>			Power cable (3.0 m/9.8 ft)	
			Lens adapter (for attaching FP-ZL034)	
			Body cap	

	Remote control
	Two AAA batteries
	Quick Start Guide

- \*1 This value represents the average value for the entire product at factory default and is based on ANSI standards.  
This is the Brightness when the FP- ZL125 optional lens is attached, Light Output Setting is set to 100%, and the picture mode is set to Bright.
- \*2 This is the brightness of the projected image center area when the FP- ZL125 optional lens is attached, Light Output Setting is set to 100%, and the picture mode is set to Bright.
- \*3 This is the estimated time until the Brightness is halved; this duration varies depending on the conditions of use and the operating environment.
- \*4 Shows the value when DynamicBlack™ is set to On.
- \*5 The noise level measurement complies with ISO 7779.

## Optional lens specifications

### FP-ZL034

<b>Model Name</b>	FP-ZL034	
<b>Lens Shift</b>	Motorized: V (Vertical) $\pm 60\%$ , H (Horizontal) $\pm 30\%$	
<b>ZOOM</b>	Motorized: 1.0x–1.2x	
<b>TR Value<sup>*1</sup></b>	0.34 (Wide end)–0.41 (Tele end)	
<b>Focal Length</b>	f=6.0 mm (Wide end)–7.2 mm (Tele end)	
<b>F-number</b>	F2.2 (wide end) – F2.41 (tele end)	
<b>Keystone Correction Angle</b>	V (vertical) max. $\pm 5^\circ$ , H (horizontal) max. $\pm 5^\circ$	
<b>Projected image size (optical)</b>	100–400 inches	
<b>Projected image size (focus adjustment)<sup>*2</sup></b>	80–1000 inches	
<b>External dimensions</b>	Width 128 × Length 341 mm	
<b>Weight</b>	Approx. 4.5 kg / Approx. 5.0 kg (including 0.5 kg lens adapter)	
<b>Operating environment</b>	<b>Operating temperature</b>	0–40 °C
	<b>Storage temperature</b>	–20–60 °C

<b>Accessories</b>	Lens front cover
	Lens rear cover
	Instruction manual

\*1 The TR (throw ratio) value is calculated by dividing the projection distance by the screen width.

\*2 When projecting beyond the projected image size (optical), the specified resolution may not be achieved across the entire screen, even if the focus is adjusted within any angle.

## FP-ZL050

<b>Model name</b>	FP-ZL050	
<b>Lens Shift</b>	Motorized: V (vertical) $\pm 53\%$ , H (horizontal) $\pm 25\%$	
<b>ZOOM</b>	Motorized: 1.0x–1.3x	
<b>TR value<sup>*1</sup></b>	0.50 (wide end)–0.65 (tele end)	
<b>Focal length</b>	f=8.99 mm (wide end)–11.6 mm (tele end)	
<b>F-number</b>	F2.0 (wide end) – F2.2 (tele end)	
<b>Keystone correction angle</b>	V (vertical) max. $\pm 10^\circ$ , H (horizontal) max. $\pm 20^\circ$	
<b>Projected image size (optical)</b>	80–300 inches	
<b>Projected image size (focus adjustment)<sup>*2</sup></b>	80–500 inches	
<b>External dimensions</b>	$\varnothing 164 \times 247$ mm (length)	
<b>Weight</b>	Approx. 2.3 kg	
<b>Operating environment</b>	<b>Operating temperature</b>	0–40 °C
	<b>Storage temperature</b>	–20–60 °C
<b>Accessories</b>	Lens Front Cover	
	Lens Rear Cover	
	Instruction Manual	

\*1 The TR (throw ratio) value is calculated by dividing the projection distance by the screen width.

\*2 When projecting beyond the projected image size (optical), the specified resolution may not be achieved across the entire screen, even if the focus is adjusted within any angle.

## FP-ZL125

<b>Model Name</b>	FP-ZL125
-------------------	----------

<b>Lens Shift</b>		Motorized: V (vertical) $\pm 55\%$ , H (horizontal) $\pm 25\%$
<b>ZOOM</b>		Motorized zoom: 1.0x–1.6x
<b>TR value<sup>*1</sup></b>		1.25 (wide end)–2.0 (tele end)
<b>Focal length</b>		f=22.1 mm (wide end)–35.5 mm (tele end)
<b>F-number</b>		F2.0 (wide end)–F2.33 (tele end)
<b>Keystone correction angle</b>		V (vertical) max. $\pm 20^\circ$ , H (horizontal) max. $\pm 40^\circ$
<b>Projected image size (optical)</b>		80–300 inches
<b>Projected image size (focus adjustment)<sup>*2</sup></b>		50–600 inches
<b>External dimensions</b>		$\varnothing 138 \times 217$ mm (length)
<b>Weight</b>		approx. 1.9 kg
<b>operating environment</b>	<b>Operating temperature</b>	0–40 °C
	<b>Storage temperature</b>	–20–60 °C
<b>Accessories</b>		Lens front cover
		Lens rear cover
		Instruction manual

\*1 The TR (throw ratio) value is calculated by dividing the projection distance by the screen width.

\*2 When projecting beyond the projected image size (optical), the specified resolution may not be achieved across the entire screen, even if the focus is adjusted within any range.

# List of Supported Resolutions

When a signal with a resolution higher than the projector's Native Resolution is input, image quality may decline.

## HDMI®1/HDMI®2/HDBaseT™

Input Signal Specifications					HDMI®1&2, HDBaseT™						
Signal Type	Signal Format	Resolution	ASPECT RATIO	Vertical Frequency (Hz)	RGB			YCbCr 4:4:4			YCbCr 4:2:2
					8 bit	10 bit	12 bit	8 bit	10 bit	12 bit	8 bit
PC	VGA	640x480	4:3	60	V	V	V	V	V	V	V
	SVGA	800x600	4:3	60	V	V	V	V	V	V	V
	XGA	1024x768	4:3	60	V	V	V	V	V	V	V
	WXGA	1280x768	15:9	60	V	V	V	V	V	V	V
	WXGA	1280x800	16:10	60	V	V	V	V	V	V	V
	SXGA-	1280x960	4:3	60	V	V	V	V	V	V	V
	SXGA	1280x1024	5:4	60	V	V	V	V	V	V	V
	WXGA	1360 x 768	16:9	60	V	V	V	V	V	V	V
	FWXGA	1366x768	16:9	60	V	V	V	V	V	V	V
	WXGA+	1440x900	16:10	60	V	V	V	V	V	V	V
	HD+	1600x900	16:9	60	V	V	V	V	V	V	V
	UXGA	1600x1200	4:3	60	V	V	V	V	V	V	V
	WSXGA+	1680x1050	16:10	60	V	V	V	V	V	V	V
	WUXGA	1920 x 1200	16:10	60	V	V	V	V	V	V	V
	UWFHD	2560x1080	21:9	24	V	V	V	V	V	V	V
25				V	V	V	V	V	V	V	
30				V	V	V	V	V	V	V	

				50	V	V	V	V	V	V	V			
				60	V	V	V	V	V	V	V			
				4K WQXGA	3840x2400	16:10	24	V	V	V	V	V	V	V
							25	V	V	V	V	V	V	V
							30	V	V	V	V	V	V	V
							50	V	-	-	V	-	-	V
							60	V	-	-	V	-	-	V
Video	EDTV (480p)	720x480	3:2	59.94	V	V	V	V	V	V	V			
				60	V	V	V	V	V	V	V			
	EDTV (576p)	720x576	5:4	50	V	V	V	V	V	V	V			
	HDTV (720p)	1280x720	16:9	50	V	V	V	V	V	V	V			
				59.94	V	V	V	V	V	V	V			
				60	V	V	V	V	V	V	V			
				120	V	V	V	V	V	V	V			
	HDTV (1080p)	1920x1080	16:9	23.98	V	V	V	V	V	V	V			
				24	V	V	V	V	V	V	V			
				25	V	V	V	V	V	V	V			
				29.97	V	V	V	V	V	V	V			
				30	V	V	V	V	V	V	V			
				50	V	V	V	V	V	V	V			
				59.94	V	V	V	V	V	V	V			
60				V	V	V	V	V	V	V				
4K	4K UHD (2160p)	3840x2160	16:9	24	V	V	V	V	V	V	V			
				25	V	V	V	V	V	V	V			
				30	V	V	V	V	V	V	V			
				50	V	-	-	V	-	-	V			
				60	V	-	-	V	-	-	V			
	DCI 4K	4096x2160	19:10	24	V	V	V	V	V	V	V			
				25	V	V	V	V	V	V	V			
				30	V	V	V	V	V	V	V			

				50	V	-	-	V	-	-	V
				60	V	-	-	V	-	-	V
High Frame Rate	1080p	1920x1080	16:9	120	V	V	V	V	V	V	V
				240	V	-	-	-	-	-	-

## 12G/3G-SDI

Input Signal Specifications						12G/3G-SDI	
Signal Type	Signal Format	Resolution	ASPECT RATIO	Vertical Frequency (Hz)	YCbCr 4:2:2		
					10 bit	12 bit	
HD-SDI	HDTV (720p)	1280x720	16:9	25	V	-	
				29.97	V	-	
				30	V	-	
				50	V	-	
				59.94	V	-	
				60	V	-	
	HDTV (1080p)	1920x1080	16:9	23.98	V	V	
				24	V	V	
				25	V	V	
				29.97	V	V	
3G-SDI Level A	HDTV (1080p)	1920x1080	16:9	30	V	V	
				50	V	-	
				59.94	V	-	
12G-SDI	UHDTV (2160p)	3840x2160	16:9	60	V	-	
				23.98	V	-	
				24	V	-	
				25	V	-	
				29.97	V	-	
				30	V	-	
				50	V	-	

				59.94	V	-
				60	V	-
	DCI 4K (2160p)	4096x2160	19:10	23.98	V	V
				24	V	V
				25	V	V
				29.97	V	V
				30	V	V
				50	V	-
				59.94	V	-
				60	V	-

---

# Throw Distance List

- ▼ Lens Shift Area and Projection Distance
- ▼ Projection Distance
  - ▼ FP-ZL034
  - ▼ FP-ZL050
  - ▼ FP-ZL125

## Lens Shift Area and Projection Distance

### Lens Shift Range

#### ■ FP-ZL034

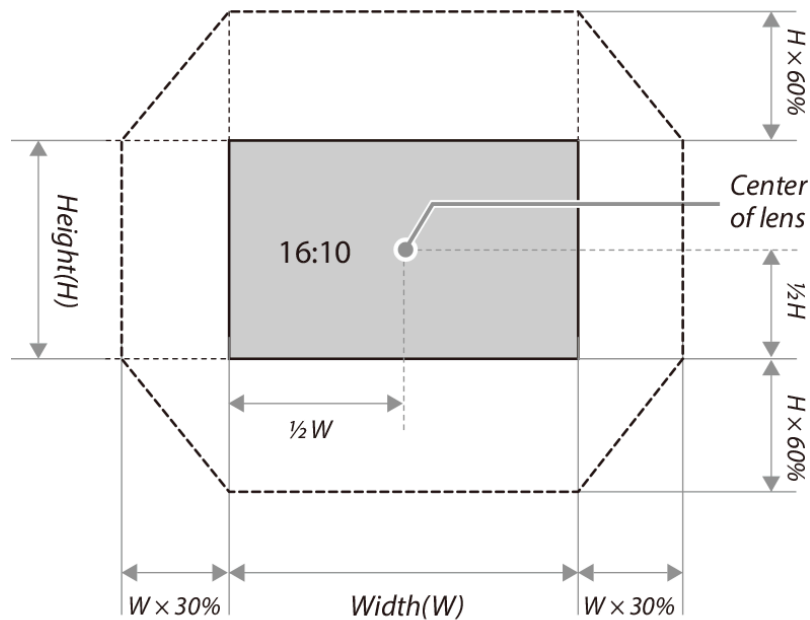

#### ■ FP-ZL050

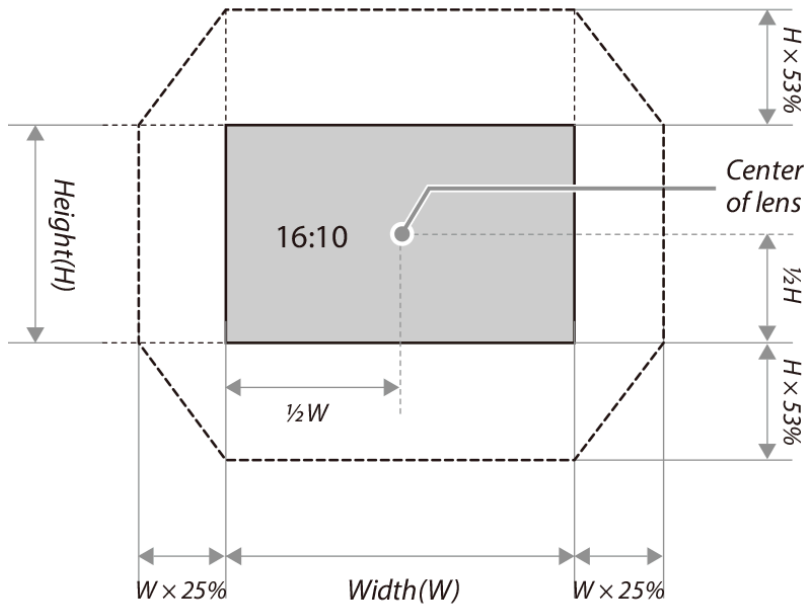

■ FP-ZL125

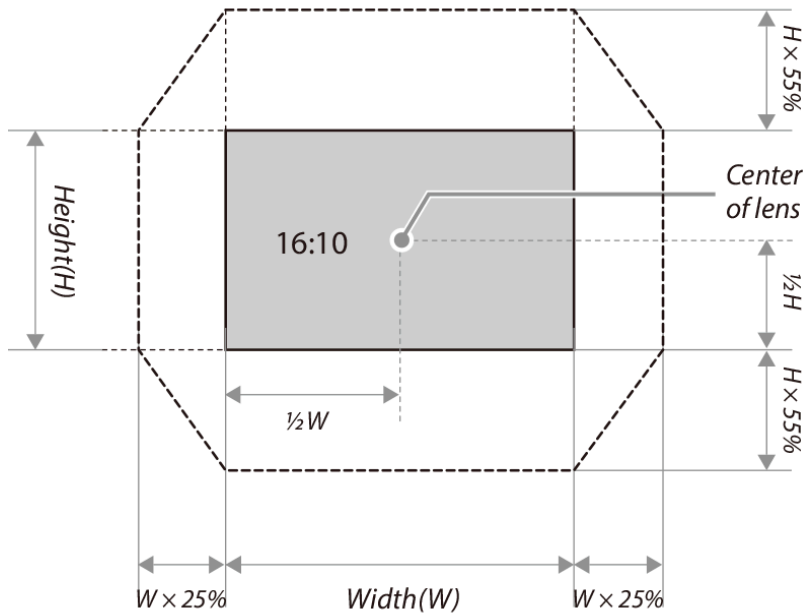

## Projection distance

### Horizontal throw distance

Advanced tools for throw distance simulation are available on our website; please use them in conjunction with this manual.

<https://optics.fujifilm.com/projector/simulator/zuh12000/en.html>

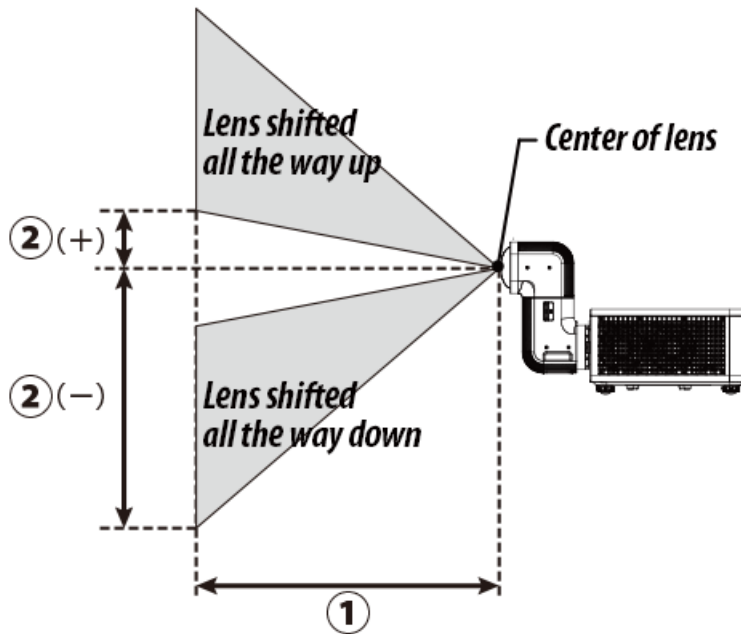

① Throw distance Minimum: Wide – Maximum:Tele (cm)

② Height from lens center to screen bottom edge (cm)

## Projection Distance Tables

### ■ FP-ZL034

16:10 screen		① Throw distance (cm/in) Wide – Tele	② Lens shift (cm/in) Bottom – Top
Screen size (inches)	Width × Height (cm/in)		
80	172 × 108	57 - 69	-118 - +11
	67.8 × 42.4	22.5 - 27.3	-46.6 - +4.2
90	194 × 121	65 - 78	-133 - +12
	76.3 × 47.7	25.5 - 30.8	-52.5 - +4.8
100	215 × 135	72 - 87	-148 - +13
	84.8 × 53.0	28.4 - 34.4	-58.3 - +5.3
120	258 × 162	87 - 105	-178 - +16
	101.8 × 63.6	34.3 - 41.4	-70.0 - +6.4
150	323 × 202	110 - 132	-222 - +20
	127.2 × 79.5	43.2 - 52.0	-87.4 - +7.9
180	388 × 242	132 - 159	-267 - +24
	152.6 × 95.4	52.0 - 62.6	-104.9 - +9.5
200	431 × 269	147 - 177	-296 - +27
	169.6 × 106.0	57.9 - 69.7	-116.6 - +10.6
250	538 × 337	185 - 222	-370 - +34
	212.0 × 132.5	72.7 - 87.4	-145.7 - +13.2

300	646 × 404 254.4 × 159.0	222 - 267 87.4 - 105.1	-444 - +40 -174.9 - +15.9
350	754 × 471 296.8 × 185.5	259 - 312 102.1 - 122.7	-518 - +47 -204.0 - +18.5
400	862 × 539 339.2 × 212.0	297 - 357 116.9 - 140.4	-592 - +54 -233.2 - +21.2

16:9 screen		① Throw distance (cm/in) Wide – Tele	② Lens shift (cm/in) bottom – top
Screen size (inches)	Width × height (cm/in)		
80	177 × 100 69.7 × 39.2	59 - 71 23.2 - 28.1	-116 - +17 -45.8 - +6.5
90	199 × 112 78.4 × 44.1	67 - 81 26.2 - 31.7	-131 - +19 -51.5 - +7.4
100	221 × 125 87.2 × 49.0	74 - 90 29.2 - 35.3	-145 - +21 -57.2 - +8.2
120	266 × 149 104.6 × 58.8	90 - 108 35.3 - 42.6	-174 - +25 -68.6 - +9.8
150	332 × 187 130.7 × 73.5	113 - 136 44.4 - 53.5	-218 - +31 -85.8 - +12.3
180	398 × 224 156.9 × 88.2	136 - 164 53.5 - 64.4	-262 - +37 -103.0 - +14.7
200	443 × 249 174.3 × 98.1	151 - 182 59.5 - 71.7	-291 - +42 -114.4 - +16.3
250	553 × 311 217.9 × 122.6	190 - 228 74.7 - 89.8	-363 - +52 -143.0 - +20.4
300	664 × 374 261.5 × 147.1	228 - 274 89.8 - 108.0	-436 - +62 -171.6 - +24.5
350	775 × 436 305.0 × 171.6	267 - 320 105.0 - 126.1	-508 - +73 -200.2 - +28.6
400	886 × 498 348.6 × 196.1	305 - 367 120.1 - 144.3	-581 - +83 -228.8 - +32.7

4:3 screen		① Throw distance (cm/in) Wide – Tele	② lens shift (cm/in) bottom – top
Screen size (inches)	width × height (cm/in)		
80	163 × 122 64.0 × 48.0	65 - 79 25.7 - 31.0	-134 - +12 -52.8 - +4.8
90	183 × 137 72.0 × 54.0	74 - 89 29.0 - 35.0	-151 - +14 -59.4 - +5.4

100	203 × 152 80.0 × 60.0	82 - 99 32.3 - 39.0	-168 - +15 -66.0 - +6.0
120	244 × 183 96.0 × 72.0	99 - 119 39.0 - 47.0	-201 - +18 -79.2 - +7.2
150	305 × 229 120.0 × 90.0	124 - 150 49.0 - 59.0	-251 - +23 -99.0 - +9.0
180	366 × 274 144.0 × 108.0	150 - 180 59.0 - 71.0	-302 - +27 -118.8 - +10.8
200	406 × 305 160.0 × 120.0	167 - 201 65.7 - 79.0	-335 - +30 -132.0 - +12.0
250	508 × 381 200.0 × 150.0	209 - 251 82.4 - 99.0	-419 - +38 -165.0 - +15.0
300	610 × 457 240.0 × 180.0	252 - 302 99.0 - 119.0	-503 - +46 -198.0 - +18.0
350	711 × 533 280.0 × 210.0	294 - 353 115.7 - 139.0	-587 - +53 -231.0 - +21.0
400	813 × 610 320.0 × 240.0	336 - 404 132.4 - 159.0	-671 - +61 -264.0 - +24.0

 **Note**

Because these are approximate calculations, the values may differ from the table above by a few percent.

**FP-ZL050**

16:10 screen		① Throw distance (cm/in)	② Lens Shift (cm/in)
Screen size (inches)	Width × Height (cm/in)	Wide – Tele	Bottom – Top
80	172 × 108 67.8 × 42.4	84 - 110 33.1 - 43.4	-111 - +3 -43.7 - +1.3
90	194 × 121 76.3 × 47.7	95 - 125 37.5 - 49.0	-125 - +4 -49.1 - +1.4
100	215 × 135 84.8 × 53.0	106 - 139 41.8 - 54.7	-139 - +4 -54.6 - +1.6
120	258 × 162 101.8 × 63.6	128 - 168 50.5 - 66.1	-166 - +5 -65.5 - +1.9
150	323 × 202 127.2 × 79.5	161 - 211 63.6 - 83.1	-208 - +6 -81.9 - +2.4

180	388 × 242 152.6 × 95.4	195 - 254 76.6 - 100.2	-250 - +7 -98.3 - +2.9
200	431 × 269 169.6 × 106.0	217 - 283 85.3 - 111.6	-277 - +8 -109.2 - +3.2
250	538 × 337 212.0 × 132.5	272 - 355 107.0 - 140.0	-347 - +10 -136.5 - +4.0
300	646 × 404 254.4 × 159.0	327 - 428 128.7 - 168.4	-416 - +12 -163.8 - +4.8
350	754 × 471 296.8 × 185.5	382 - 500 150.5 - 196.8	-485 - +14 -191.1 - +5.6
400	862 × 539 339.2 × 212.0	437 - 572 172.2 - 225.2	-555 - +16 -218.4 - +6.4

16:9 screen		① Throw distance (cm/in)	② Lens shift (cm/in)
Screen size (inches)	Width × Height (cm/in)	Wide – Tele	Bottom – Top
80	177 × 100 69.7 × 39.2	86 - 113 34.1 - 44.6	-108 - +9 -42.7 - +3.5
90	199 × 112 78.4 × 44.1	98 - 128 38.5 - 50.4	-122 - +10 -48.0 - +3.9
100	221 × 125 87.2 × 49.0	109 - 143 43.0 - 56.3	-136 - +11 -53.4 - +4.4
120	266 × 149 104.6 × 58.8	132 - 173 51.9 - 67.9	-163 - +13 -64.1 - +5.2
150	332 × 187 130.7 × 73.5	166 - 217 65.3 - 85.5	-203 - +17 -80.1 - +6.5
180	398 × 224 156.9 × 88.2	200 - 262 78.7 - 103.0	-244 - +20 -96.1 - +7.8
200	443 × 249 174.3 × 98.1	223 - 291 87.7 - 114.6	-271 - +22 -106.8 - +8.7
250	553 × 311 217.9 × 122.6	279 - 365 110.0 - 143.8	-339 - +28 -133.5 - +10.9
300	664 × 374 261.5 × 147.1	336 - 440 132.3 - 173.0	-407 - +33 -160.2 - +13.1
350	775 × 436 305.0 × 171.6	393 - 514 154.7 - 202.2	-475 - +39 -186.8 - +15.3
400	886 × 498 348.6 × 196.1	450 - 588 177.0 - 231.4	-542 - +44 -213.5 - +17.4

4:3 screen		① Throw distance (cm/in) Wide – Tele	② lens shift (cm/in) bottom – top
Screen size (inches)	width × height (cm/in)		
80	163 × 122 64.0 × 48.0	86 - 113 34.1 - 44.6	-126 - +4 -49.4 - +1.4
90	183 × 137 72.0 × 54.0	98 - 128 38.5 - 50.4	-141 - +4 -55.6 - +1.6
100	203 × 152 80.0 × 60.0	109 - 143 43.0 - 56.3	-157 - +5 -61.8 - +1.8
120	244 × 183 96.0 × 72.0	132 - 173 51.9 - 67.9	-188 - +5 -74.2 - +2.2
150	305 × 229 120.0 × 90.0	166 - 217 65.3 - 85.5	-235 - +7 -92.7 - +2.7
180	366 × 274 144.0 × 108.0	200 - 262 78.7 - 103.0	-283 - +8 -111.2 - +3.2
200	406 × 305 160.0 × 120.0	223 - 291 87.7 - 114.6	-314 - +9 -123.6 - +3.6
250	508 × 381 200.0 × 150.0	279 - 365 110.0 - 143.8	-392 - +11 -154.5 - +4.5
300	610 × 457 240.0 × 180.0	336 - 440 132.3 - 173.0	-471 - +14 -185.4 - +5.4
350	711 × 533 280.0 × 210.0	393 - 514 154.7 - 202.2	-549 - +16 -216.3 - +6.3
400	813 × 610 320.0 × 240.0	450 - 588 177.0 - 231.4	-628 - +18 -247.2 - +7.2

 **Note**

Because these are approximate calculations, the values may differ from the table above by a few percent.

**FP-ZL125**

16:10 screen		① Throw distance (cm/in) Wide – Tele	② Lens shift (cm/in) Bottom – Top
Screen size (inches)	Width × Height (cm/in)		
80	172 × 108 67.8 × 42.4	211 - 344 83.2 - 135.3	-113 - +5 -44.5 - +2.1
90	194 × 121 76.3 × 47.7	239 - 387 94.0 - 152.5	-127 - +6 -50.1 - +2.4

100	215 × 135 84.8 × 53.0	266 - 431 104.8 - 169.8	-141 - +7 -55.6 - +2.6
120	258 × 162 101.8 × 63.6	321 - 519 126.3 - 204.3	-170 - +8 -66.8 - +3.2
150	323 × 202 127.2 × 79.5	403 - 650 158.5 - 256.0	-212 - +10 -83.5 - +4.0
180	388 × 242 152.6 × 95.4	485 - 782 190.8 - 307.8	-254 - +12 -100.2 - +4.8
200	431 × 269 169.6 × 106.0	539 - 869 212.3 - 342.2	-283 - +13 -111.3 - +5.3
250	538 × 337 212.0 × 132.5	676 - 1088 266.1 - 428.5	-353 - +17 -139.1 - +6.6
300	646 × 404 254.4 × 159.0	812 - 1307 319.8 - 514.7	-424 - +20 -166.9 - +7.9
350	754 × 471 296.8 × 185.5	949 - 1526 373.6 - 600.9	-495 - +24 -194.8 - +9.3
400	862 × 539 339.2 × 212.0	1085 - 1745 427.3 - 687.2	-565 - +27 -222.6 - +10.6

16:9 screen		① Throw distance (cm/in)	② Lens shift (cm/in)
Screen size (inches)	Width × Height (cm/in)	Wide – Tele	bottom – top
80	177 × 100 69.7 × 39.2	218 - 352 85.8 - 138.5	-111 - +11 -43.6 - +4.4
90	199 × 112 78.4 × 44.1	246 - 397 96.9 - 156.2	-125 - +12 -49.0 - +4.9
100	221 × 125 87.2 × 49.0	274 - 442 107.9 - 173.8	-138 - +14 -54.5 - +5.4
120	266 × 149 104.6 × 58.8	330 - 531 130.1 - 209.1	-166 - +17 -65.4 - +6.5
150	332 × 187 130.7 × 73.5	415 - 666 163.3 - 262.1	-208 - +21 -81.7 - +8.2
180	398 × 224 156.9 × 88.2	499 - 800 196.5 - 315.0	-249 - +25 -98.1 - +9.8
200	443 × 249 174.3 × 98.1	555 - 890 218.6 - 350.3	-277 - +28 -108.9 - +10.9
250	553 × 311 217.9 × 122.6	696 - 1114 274.0 - 438.6	-346 - +35 -136.2 - +13.6

300	664 × 374 261.5 × 147.1	836 - 1338 329.3 - 526.8	-415 - +42 -163.4 - +16.3
350	775 × 436 305.0 × 171.6	977 - 1562 384.7 - 615.0	-484 - +48 -190.7 - +19.1
400	886 × 498 348.6 × 196.1	1118 - 1786 440.0 - 703.3	-553 - +55 -217.9 - +21.8

4:3 screen		① Throw distance (cm/in) Wide – Tele	② Lens Shift (cm/in) bottom – top
Screen size (inches)	Width × Height (cm/in)		
80	163 × 122 64.0 × 48.0	199 - 322 78.4 - 126.8	-128 - +6 -50.4 - +2.4
90	183 × 137 72.0 × 54.0	225 - 363 88.5 - 142.9	-144 - +7 -56.7 - +2.7
100	203 × 152 80.0 × 60.0	251 - 404 98.7 - 159.1	-160 - +8 -63.0 - +3.0
120	244 × 183 96.0 × 72.0	302 - 486 119.0 - 191.5	-192 - +9 -75.6 - +3.6
150	305 × 229 120.0 × 90.0	380 - 610 149.4 - 240.0	-240 - +11 -94.5 - +4.5
180	366 × 274 144.0 × 108.0	457 - 733 179.9 - 288.6	-288 - +14 -113.4 - +5.4
200	406 × 305 160.0 × 120.0	509 - 815 200.2 - 320.9	-320 - +15 -126.0 - +6.0
250	508 × 381 200.0 × 150.0	637 - 1021 251.0 - 401.8	-400 - +19 -157.5 - +7.5
300	610 × 457 240.0 × 180.0	766 - 1226 301.7 - 482.7	-480 - +23 -189.0 - +9.0
350	711 × 533 280.0 × 210.0	895 - 1432 352.5 - 563.6	-560 - +27 -220.5 - +10.5
400	813 × 610 320.0 × 240.0	1024 - 1637 403.2 - 644.5	-640 - +30 -252.0 - +12.0

 **Note**

Because these are approximate calculations, the values may differ from the table above by a few percent.

# Geometric Distortion Correction Area

Numerical values are subject to an error of several percent due to approximate calculation. As the correction amount increases, it may become difficult to achieve focus.

The correction range is based on a Lens Shift position of V (vertical)± 0% and H (horizontal)± 0%.

Optional lens model number	Keystone Correction		Curved screen correction			
	① Horizontal Keystone	② Vertical Keystone	③ Horizontal Concave	④ Vertical Concave	⑤ Horizontal Convex	⑥ Vertical Convex
	A Correction Angle	B Correction Angle	R/L Minimum Value	R/L Minimum Value	R/L Minimum Value	R/L Minimum Value
FP-ZL034	±5°	±5°	1.50	1.41	4.73	2.14
FP-ZL050	±20°	±10°	1.24	0.80	4.33	1.67
FP-ZL125	±40°	±20°	0.35	0.20	0.59	0.32

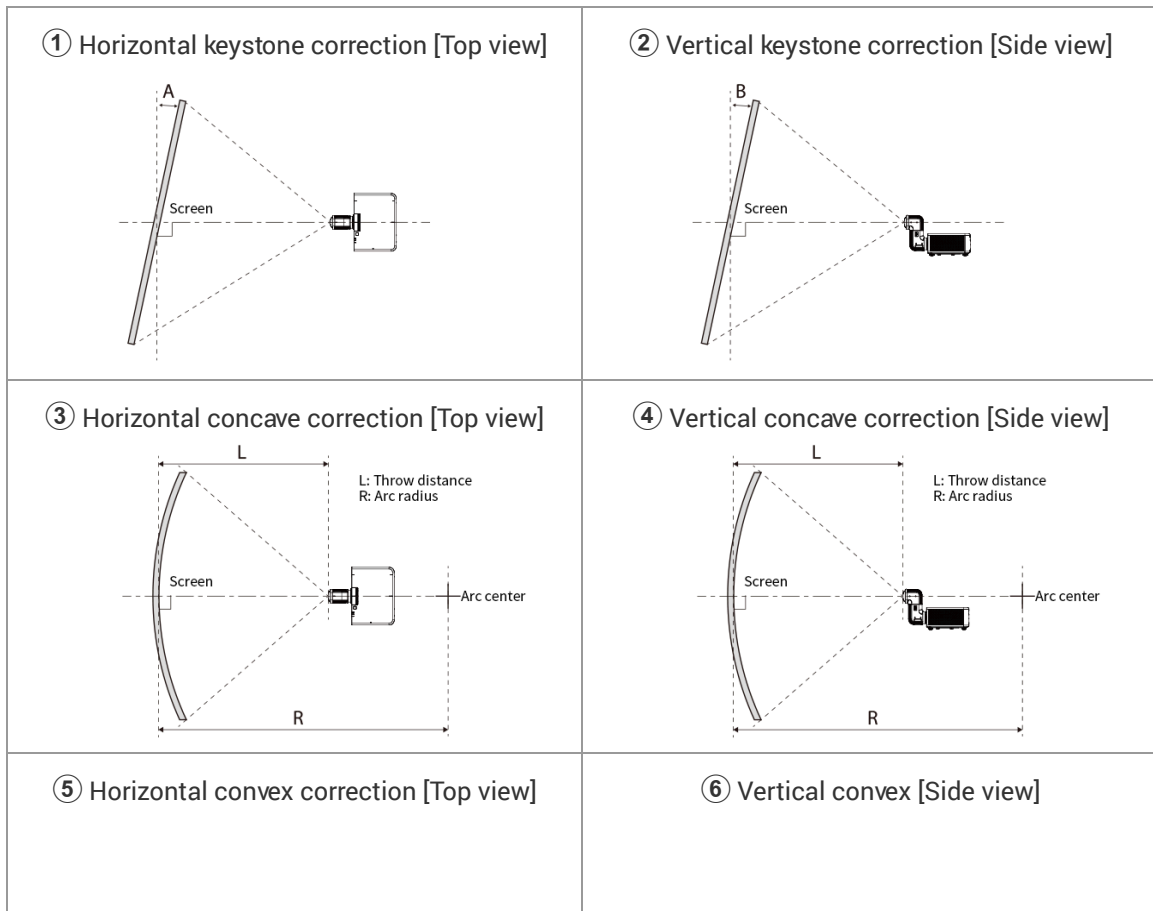

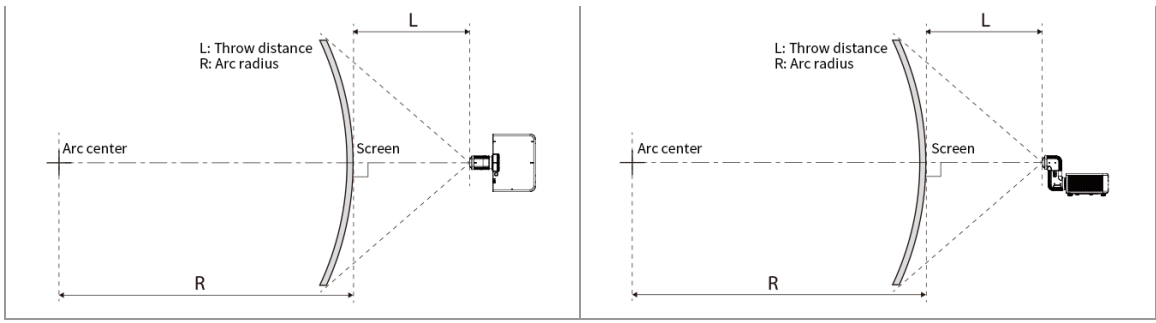

# PJLink Commands

This projector complies with the PJLink Class2 standard established by JBMIA. You can use the PJLink protocol to configure the projector or check its status from a PC.

- To use PJLink, configure the network settings in advance.
- For PJLink specifications, please refer here.

<https://pjlink.jbmia.or.jp/>

---

# Projector Control

The projector can be controlled by sending commands through the control terminal or LAN terminal.

## control terminal

Item	RS-232C	HDBaseT		LAN
		RS-232C	LAN	
Connection cable	D-sub 9-pin	RJ45 (Category 5e or higher)		RJ45
Communication mode	RS-232C asynchronous, half-duplex communication		TCP: Port 3023	
Baud Rate	9600 - 115200	115200		-
Data Bits	8-bit		-	
Parity check	None		-	
Stop bits	1-bit		-	
Flow control	None		-	

## Control Commands

### Write Command

#### ■ Type-1

[	X	X	X	X	n	]
Prefix	Command				0~9999	Suffix

#### ■ Type-2

[	X	X	X	X	n	+	X	X	X	X	n	]
prefix	Command				0~9999	+	sub command				0~9999	suffix

### Note

In the event of an error, the following response is returned.

- In case of an unknown command  
[ERR "00000 XXXX: control not found"]
- For unknown parameter  
[ERR "00000 XXXX: invalid value"]
- When command disabled  
[ERR "00000 XXXX: disabled control"]

## Read Command

[	X	X	X	X	?	]
prefix	Command				inquiry code	suffix

response format

[	X	X	X	X	!	n	]
prefix	Command				Separator	0-9999	suffix

## Command List

← [FP-ZUH12000 Control Command List](#)

# Web Control

You can use a web browser to monitor the status and control this unit connected to a network.

- ▼ [About the web control function](#)
- ▼ [How to Use the Web Control Function](#)
- ▼ [Functions Available Only Through Web Control](#)

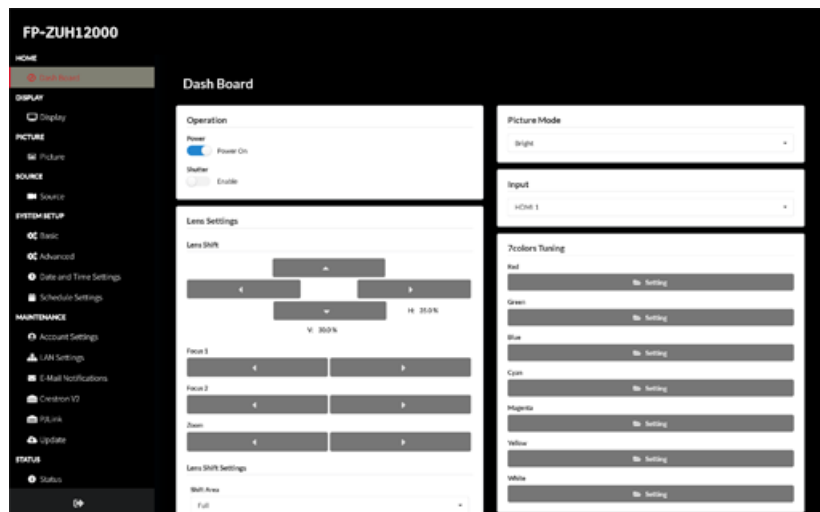

## About the web control function

The following operations can be performed from a PC using the web control function.

- Projector Setup and Adjustment
  - Backing Up and Restoring Projector Setup Values
  - Monitoring Projector Status
  - Sending Email During Projector Abnormalities
- \*An email server is required on a network with which the Projector can communicate to use the email sending function.

## How to Use the Web Control Function

### Preparing the web control function

To use the web control function, the following settings are required. The PC and projector must also be connected to a network that allows communication.

- Configure the **LAN Settings** so that the projector and PC can communicate.
- To use the projector even in standby mode, set **STANDBY MODE to Communications**.
- Enable **HTTP** in the projector's **LAN Control**.

## Accessing the Web Control Function

- 1** In the web browser's address bar, enter the IP address set on the projector.

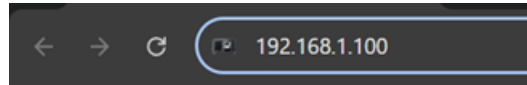

- 2** Enter the user name and password on the login screen.  
By default, the following two types of user names are set.  
There is no password by default.

admin	All web control functions are available.
user	Basic operations of the web control functions are available.

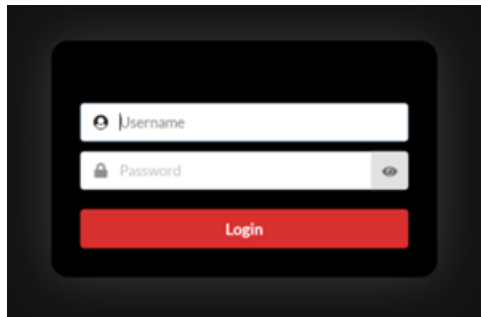

- 3** The password setup screen will be displayed when you log in for the first time.  
Enter the password you want to set twice and press the SAVE button.  
The login screen will be displayed again; enter your user name and the password you have set.

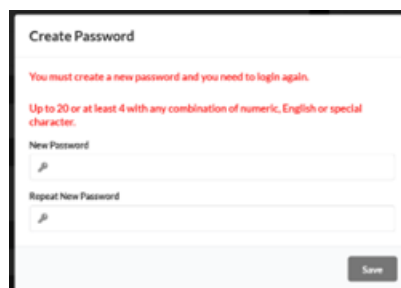
A screenshot of a "Create Password" screen. At the top, it says "Create Password". Below that, there are two lines of red text: "You must create a new password and you need to login again." and "Up to 20 or at least 4 with any combination of numeric, English or special character." There are two input fields: "New Password" and "Repeat New Password". At the bottom right, there is a "Save" button.

### Caution

The set password will be deleted when  **System Setup: Basic > Reset Settings > Initialization** is executed from the menu screen.

**4** The web control screen is displayed upon successful login.

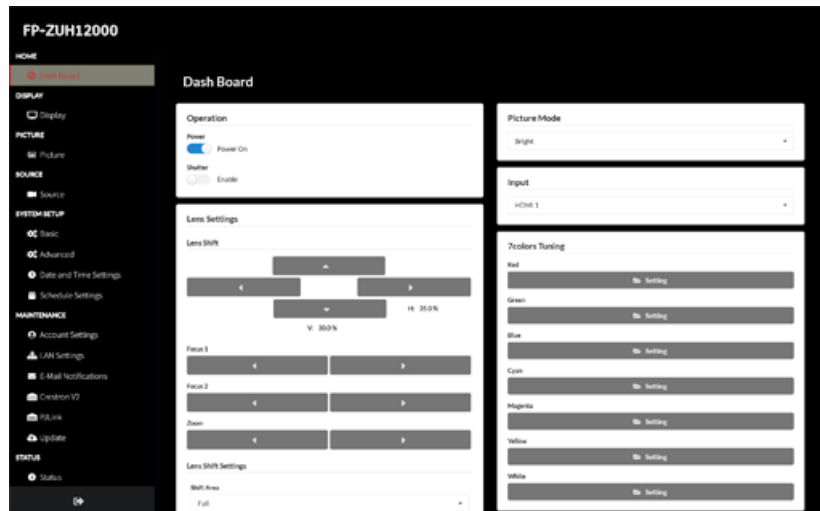

## Functions Available Only Through Web Control

### Uploading Custom EDID

Select Source under SOURCE in the navigation menu.

Select Upload in the EDID Settings and upload the custom EDID file.

#### Note

The file to be uploaded must be EDID Block 0/Block 1 (256-byte) data.

Custom EDID can be used by selecting Custom in the EDID Settings of the input menu.

### Uploading a custom background color

Select Basic under System Setup in the navigation menu.

Select Upload in Background Color and upload the file.

The uploadable file is a 3840×2400 PNG file.

#### Note

The custom background color can be used by selecting Custom in Background Color in the Basic System Setup menu.

## Backup and restore settings

---

In the navigation menu, select Advanced under System Setup.

To back up, select Backup in User Settings and download the settings file.

To restore, select Restore in User Settings and upload the settings file downloaded with Backup.

## Email Notification Function

---

In the navigation menu, select E-Mail Notifications under Maintenance.

Enter the required setup values for notification on the screen.

An email server is required on a network the projector can communicate with.  
Contact your email server administrator for setup details.

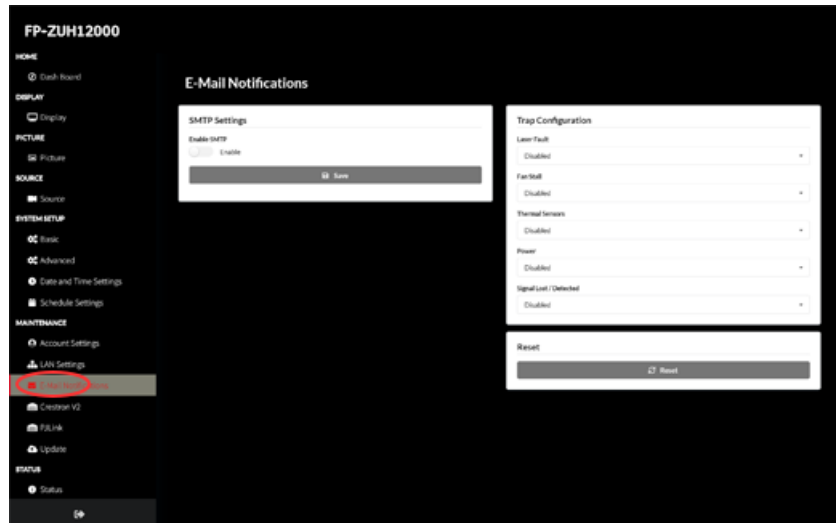

## Crestron Connected® settings

---

In the navigation menu, select Crestron® V2 under Maintenance.

Enter the required setting values.

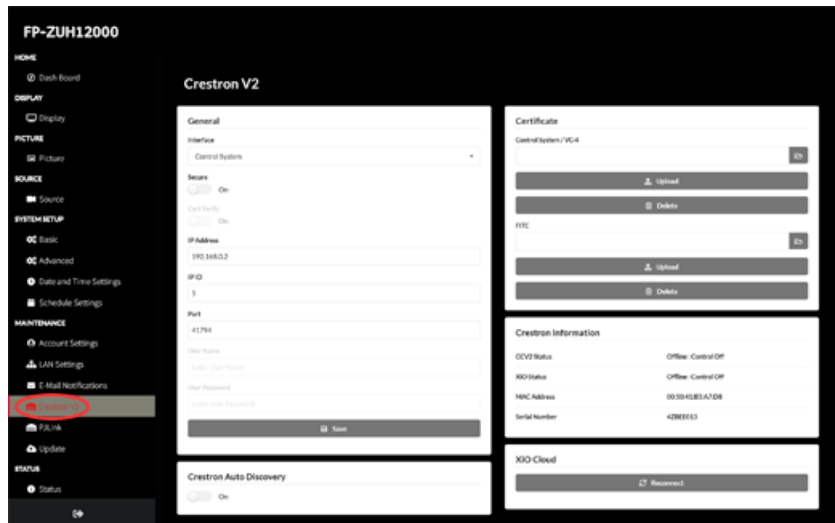

## PJLink™ settings

Select PJLink™ under Maintenance in the navigation menu.

Input the required Setup values.

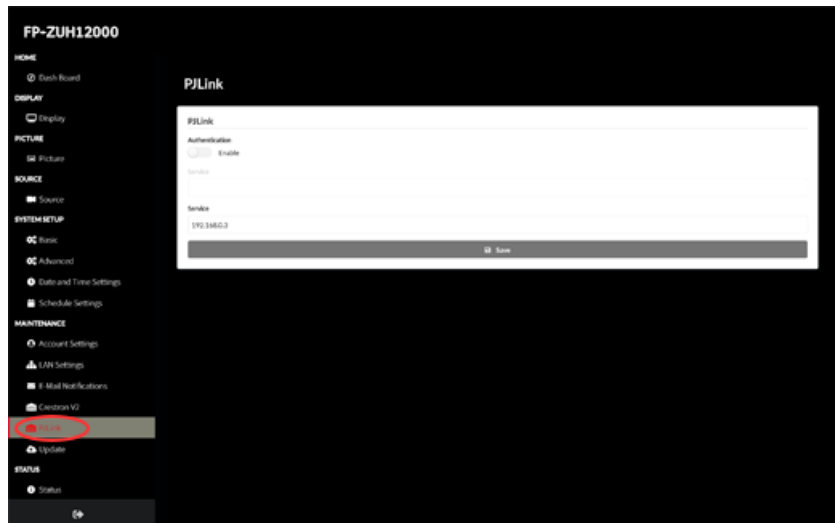

## Firmware Update

**1** Select Update under Maintenance in the navigation menu.

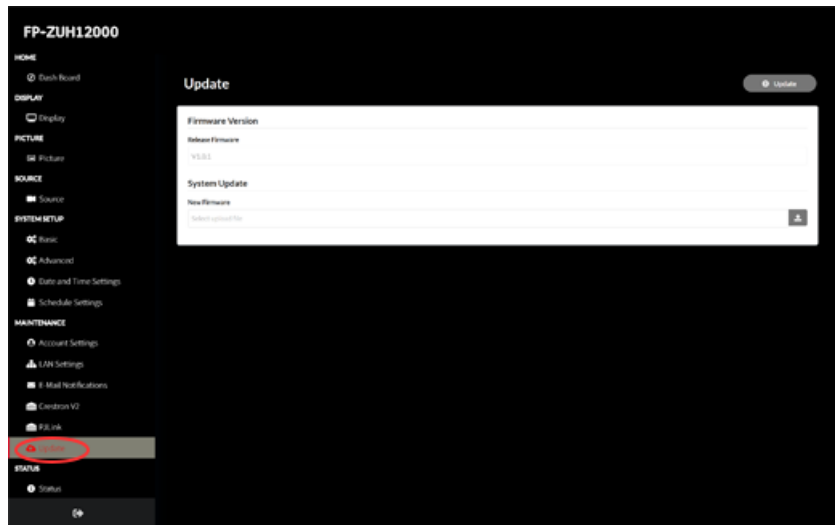

2 Specify the downloaded firmware file and press the Update button on the top right.

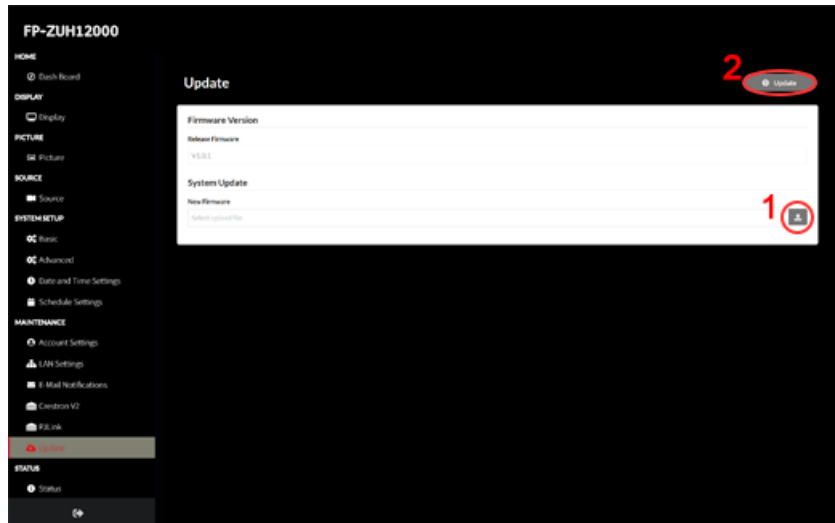

3 The firmware update confirmation screen will be displayed; press the Yes button.

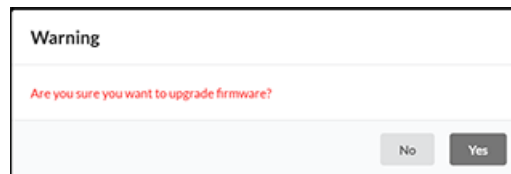

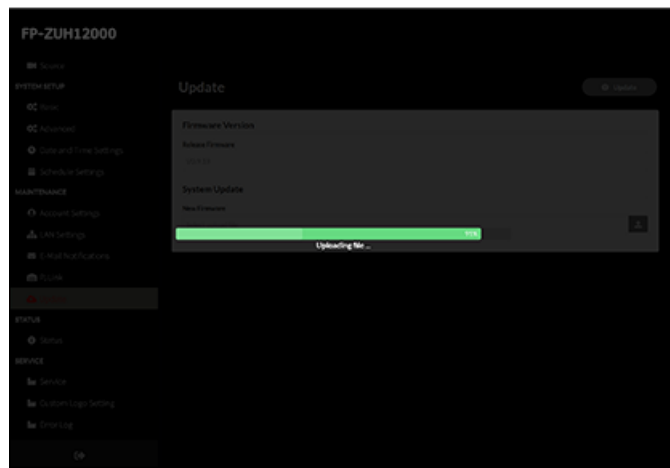

**4** If the firmware update is successful, the Projector will restart automatically.

**⚠ Caution**

The firmware update takes a maximum of 20 minutes. Do not perform any menu operation while updating the firmware.  
Also, never turn off the main unit power supply

# Trademarks

- The PJLink™ trademark is a registered or pending trademark in Japan, the United States, and other countries or regions.
  - HDBaseT™ and the HDBaseT™ logo are trademarks of the HDBaseT Alliance in Japan and other countries.
  - DLP® and the DLP® logo are registered trademarks of Texas Instruments.
  - HDMI® is a trademark or registered trademark of HDMI Licensing LLC in the United States and other countries.
  - Crestron®, Crestron RoomView®, Crestron Connected®, and the Crestron connected® logo are registered trademarks of Crestron Electronics, Inc. in the United States.
  - AMX® is a registered trademark of Harman Professional, Inc. in the United States.
  - Extron® is a trademark or registered trademark of RGB Systems, Inc. in the United States and other countries.
-

# License

Licenses are described on the following pages:

[👉 licenses](#)

---