

FUJIFILM

Surveillance Camera

FUJIFILM SX-800

Owner's Manual: IP ONVIF ConnectionsP

FUJIFILM Corporation

BL00005029-200(1)

Table of Contents

Safety Precautions	1
For Your Safety	1
⚠ WARNINGS	1
⚠ CAUTIONS	1
General Precautions	1
NOTICES	2
Caution:	2
FCC Warning:	2
For Customers In Canada	2
About the Icons	2
Disposal of Electrical and Electronic Equipment in Private Households In the European Union, Norway, Iceland and Liechtenstein:	3
Precautions for Use	4
Operating Environment	4
Installation	4
Use	4
Network Settings	4
Introduction	5
Parts of the Camera	5
The Control Panel	5
Installation and Connection	6
Installation	6
Screw Hole Specifications	6
Connection Schematic	7
Operating Mode Selection: DIP Switches	7
Connecting to a Computer	8
Viewing and Recording the Live Feed	9
Launching a Web Browser	9

Preferences	10
CAMERA SETTING	11
AF SETTING	11
FOCUS AREA	11
AF SENSITIVITY	11
IRIS	11
SHUTTER SPEED	11
GAIN	11
DAY/NIGHT	12
EXTERNAL TRIGGER	12
IR WAVELENGTH	12
IMAGE STABILIZATION	13
IMAGE QUALITY SETTING	14
OPTICAL FILTER (VLC)	14
WDR	14
BACKLIGHT CORRECTION	14
HEAT HAZE REDUCTION	14
FOG REDUCTION	14
NOISE REDUCTION	14
DIGITAL ZOOM	14
USE SETTING	15
BRIGHTNESS	15
CONTRAST	15
SATURATION	15
SHARPNESS	15
WHITE BALANCE	15
SYSTEM	16
MODEL NAME	16
SERIAL NO.	16
FW VER.	16
APPLICATION VER.	16
TIME ZONE	16
IN-CAMERA TIME SETTING	16
ABOUT DEVICE	16

PTZ SETTING	17
RS485 BAUD RATE.....	17
RS485 ID.....	17
RS485 TERMINATION.....	17
Pelco-P/Pelco-D.....	17
SYSTEM MAINTENANCE	18
REBOOT.....	18
RESET SETTINGS.....	18
IMPORT CONFIGURATION FILE.....	18
EXPORT TO CONFIGURATION FILE.....	18
FW UPDATE.....	18
COPY LOG DATA.....	18
NETWORK SETTING	19
IPv4 ADDRESS.....	19
IPv4 SUBNET MASK.....	19
IPv4 DEFAULT GATEWAY.....	19
MAC ADDRESS.....	19
IPv4 MTU.....	19
PRIMARY DNS SERVER.....	19
SECONDARY DNS SERVER.....	19
IPv4 ADDRESS.....	19
DISPLAY/OSD SETTING	20
DATE DISPLAY.....	20
TIME DISPLAY.....	20
DATE DISPLAY FORMAT.....	20
言語/LANG	20
言語/LANG.....	20

Troubleshooting 21

Defaults 22



CAMERA SETTING.....	22
IMAGE QUALITY SETTING.....	22
SYSTEM.....	22
PTZ SETTING.....	22
SYSTEM MAINTENANCE.....	22
NETWORK SETTING.....	22
DISPLAY/OSD SETTING.....	22
言語/LANG.....	22

Specifications 23

Safety Precautions

For Your Safety

This section lists important precautions that must be followed to ensure safe and correct use of the product. Read them before using the product and observe them during use.

The  **WARNING** and  **CAUTION** indications in this document indicate the following:

 **WARNINGS** Failure to observe warnings could result in death or serious injury.

 **CAUTIONS** Failure to observe cautions could result in injury or property damage.

WARNINGS

- Take all steps necessary to prevent water entering the product. Failure to observe this precaution could result in fire or electric shock. Should water find its way in, disconnect the power source immediately.
- Be sure the product is installed securely. Serious accidents could result should the product fall from a height.
- When working in high places, work with a partner or partners, use a safety line, and take all other precautions necessary to ensure safety. Slipping, falling, or loss of balance could result in serious accidents.
- When installing the camera in high places, ensure that people below keep their distance. Falling objects could cause serious accidents.
- Ensure that the surface on which the camera is installed is level. Failure to observe this precaution could cause the camera to fall, potentially causing serious accidents.

CAUTIONS

- Keep the product out of direct sunlight.
- Do not turn the product on without first confirming that the power supply is connected correctly.
- The product could cause injury if dropped during transport. Take all precautions necessary to ensure that the product is not dropped.
- Ensure that the voltage of the power supply matches the product's rated voltage. Incorrect voltages could damage the product or result in fire or electric shock.
- When connecting or disconnecting the power cable, hold the plug and not the cable. Damage to the cable could result in fire or electric shock.
- Should you detect any abnormalities such as smoke, unusual noises or smells, or the presence of foreign matter inside the product, disconnect the power supply immediately and contact the original retailer.
- Do not disassemble or modify. Failure to observe this precaution could result in electric shock or product malfunction. Malfunctions or damage resulting from customers disassembling or modifying the product are not covered under warranty.
- Do not aim the camera at the sun. Direct sunlight focused through the lens could damage the product's internal parts.
- Install the camera base down. Installing the camera in other orientations could lead to warping that may impair product performance.

General Precautions

- Use the product only as described in this manual.
- The camera and its accessories are precision devices. Under no circumstances should they be subjected to excessive force.
- Install the camera in a housing or other location where it will not be exposed to rain, wind, dust, or direct sunlight.
- Bringing the camera abruptly from a cold location to a warm and humid environment could cause the lens to fog. Take measures to allow the camera to adapt to the new environment before subjecting it to changes in temperature and humidity.
- Replace the cap if the camera will not be used for an extended period.
- The camera lens has a special anti-reflective coating. As a result, the back of the lens may appear spotted, but this has no effect on performance.

NOTICES

Verification

Model Number: SX800

Trade Mark: Fujifilm

This device complies with Part 15 of the FCC Rules.

Operation is subject to the following two conditions:

(1) This device may not cause harmful interference, and (2) this device must accept any interference received, including interference that may cause undesired operation.

Caution:

This equipment has been tested and found to comply with the limits for a Class A digital device, pursuant to part 15 of the FCC Rules.

These limits are designed to provide reasonable protection against harmful interference when the equipment is operated in a commercial environment.

This equipment generates, uses, and can radiate radio frequency energy and, if not installed and used in accordance with the instruction manual, may cause harmful interference to radio communications. Operation of this equipment in a residential area is likely to cause harmful interference in which case the user will be required to correct the interference at his own expense.

FCC Warning:

To assure continued compliance, follow the attached installation instructions. This includes using the provided power cord and shielded interface cables when connecting to computer or peripheral devices. Also, any unauthorized changes or modifications to this equipment could void the user's authority to operate this device.

For Customers In Canada

CAN ICES-3(A)/NMB-3(A)

WARNING: This equipment is compliant with Class A of CISPR32. In a residential environment this equipment may cause radio interference.

This product complies with the following EU Directives:

- RoHS Directive 2011/65/EU
- EMC Directive 2014/30/EU

Compliance with these directives implies conformity to applicable harmonized European standards (European Norms) which are listed on the EU Declaration of Conformity issued by FUJIFILM Corporation for this product or product family.



This compliance is indicated by the following conformity marking placed on the product:



This marking is valid for non-Telecom products and EU harmonized Telecom products (e.g. Bluetooth).

About the Icons

The symbols on the product represent the following:

	AC
	DC
	Class II equipment (The construction of the product is double-insulated.)

Disposal of Electrical and Electronic Equipment in Private Households In the European Union, Norway, Iceland and Liechtenstein:

This symbol on the product, or in the manual and in the warranty, and/or on its packaging indicates that this product shall not be treated as household waste. Instead it should be taken to an applicable collection point for the recycling of electrical and electronic equipment. By ensuring this product is disposed of correctly, you will help prevent potential negative consequences to the environment and human health, which could otherwise be caused by inappropriate waste handling of this product.



Precautions for Use

Operating Environment

- The camera can be used at temperatures of from –10 to +50 °C (temperatures below freezing are only supported if the power supply is not interrupted) and at humidities of from 10 to 80% (no condensation).
- Prolonged use at high temperatures or humidities could degrade components, shortening product life.
- Do not install the product where it will be exposed to solvents or other chemicals.

Installation

- Do not install LAN or audio cables in close proximity to cables for fluorescent lights or other electrical devices. Failure to observe this precaution could impair sound or image quality. Move the cables if signal quality is affected.
- Using the product in close proximity to powerful electromagnetic fields, such as those produced by television transmitter antennas, electric motors, or transformers, could result in distorted or wavy pictures. Should this occur, use steel cable shielding.
- Use a Category 5 or better shielded twisted pair (STP) LAN cable for LAN connections.
- Plastic cable insulation may sometimes be damaged by crows or other birds. Protect cables using a cable conduit.
- Fix cables in place so that they are not subject to repeated vibration, friction, or tugging. Failure to observe this precaution could cause the cable to break.
- Install the product base down.

Use

- Do not aim the lens directly at the sun or other bright light sources or reflections. Failure to observe this precaution could result in deterioration of the image sensor color filter, affecting picture color.
- Do not subject the product to strong physical shocks or vibration. Failure to observe this precaution could result in product malfunction.
- Clean the product with a soft, dry cloth. Never use chemically-treated cloths or solvents such as benzine (petroleum ether), thinner, or alcohol. Failure to observe this precaution could cause warping or discoloration.

Network Settings

- You will need to supply an IP address, subnet mask, and gateway IP address.
- The frame rate may drop if multiple streams are transmitted via unicast.
- When connected to multiple devices, the product will transmit data to all devices at the rate supported by the device with the slowest receiving rate.

Introduction

Parts of the Camera

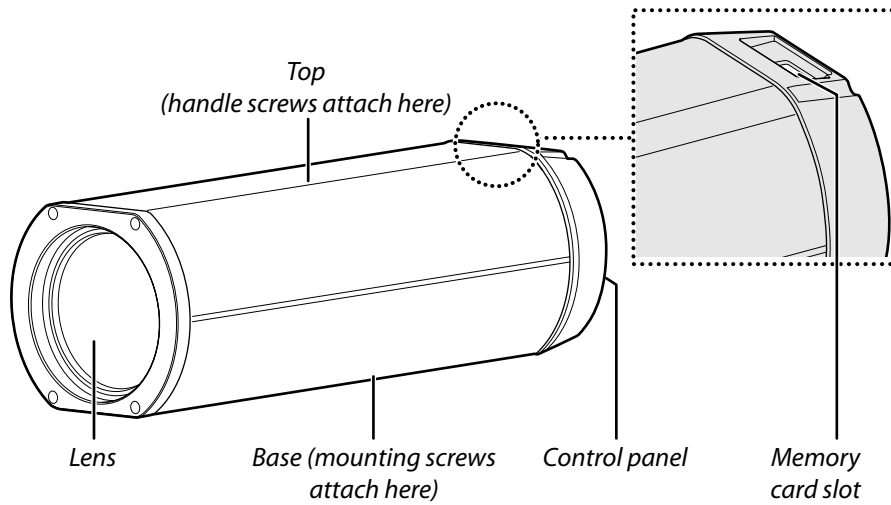

The Control Panel

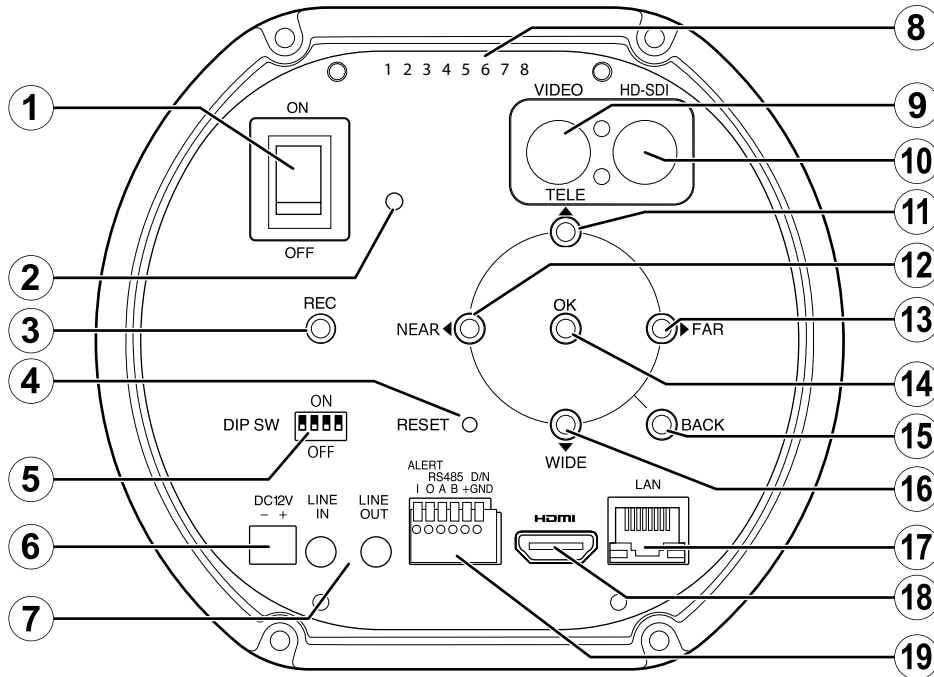

Item	Name
①	Power switch
②	Power lamp
③	REC (record) button
④	RESET button
⑤	DIP switches (4 bits)
⑥	Power connector
⑦	Audio input/output connectors
⑧	Serial number
⑨	Video output connector
⑩	HD-SDI output connector

Item	Name
⑪	TELE button
⑫	NEAR button
⑬	FAR button
⑭	OK/MENU button
⑮	BACK button
⑯	WIDE button
⑰	LAN connector
⑱	HDMI connector
⑲	Six-pin connector

Installation and Connection

Installation

Use the screw holes on the base to secure the camera to a mount or other surface.

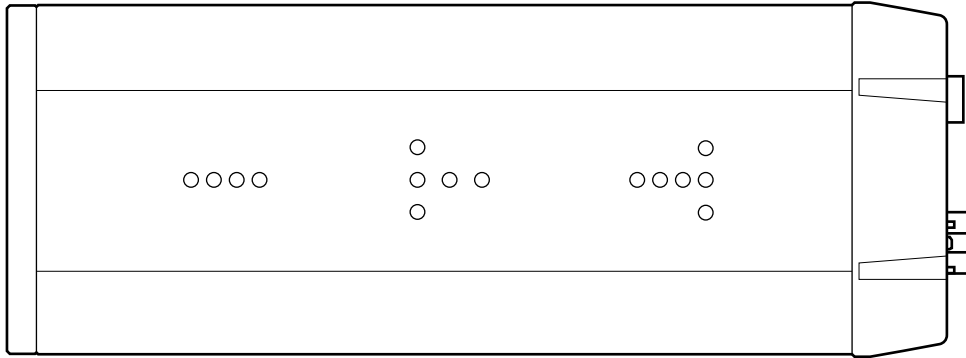

WARNING

Attach the product securely to a surface that can safely bear the combined weight of the camera and associated hardware. Do not mount the camera in unstable locations or locations subject to frequent vibration or attach it to weak materials such as drywall, ALC (autoclaved lightweight concrete), concrete blocks, or plywood. Injury could result should the product fall from its mounting.

CAUTIONS

- Use ¼", UNC 20 thread screws with a thread engagement length of 6.5 to 10 mm.
- Install the camera base down.

A handle can be attached using the screws on top of the camera.

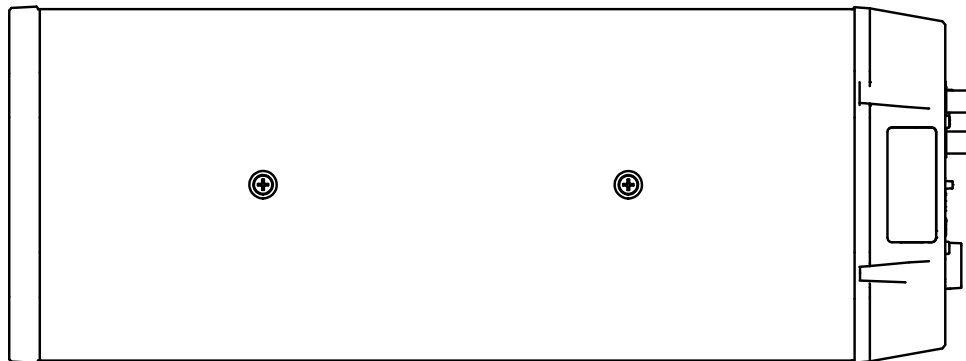

CAUTIONS

- Use M4 screws with a thread engagement length of at least 4 mm and a protrusion of no more than 6 mm.
- Do not use the screw holes on top of the camera for any other purpose.

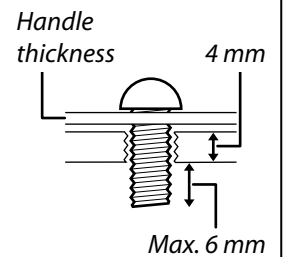

Screw Hole Specifications

The specifications for the screw holes on the top and base of the camera are as follows:

	Type	Quantity	Depth	Tightening torque
Top	M4	2	Pass through (threaded depth 4 mm)	80–100 N·cm
Base	¼", UNC 20 thread	15	10 mm	240–300 N·cm

Connection Schematic

The schematic below illustrates how the camera can be installed for use with IP connections.

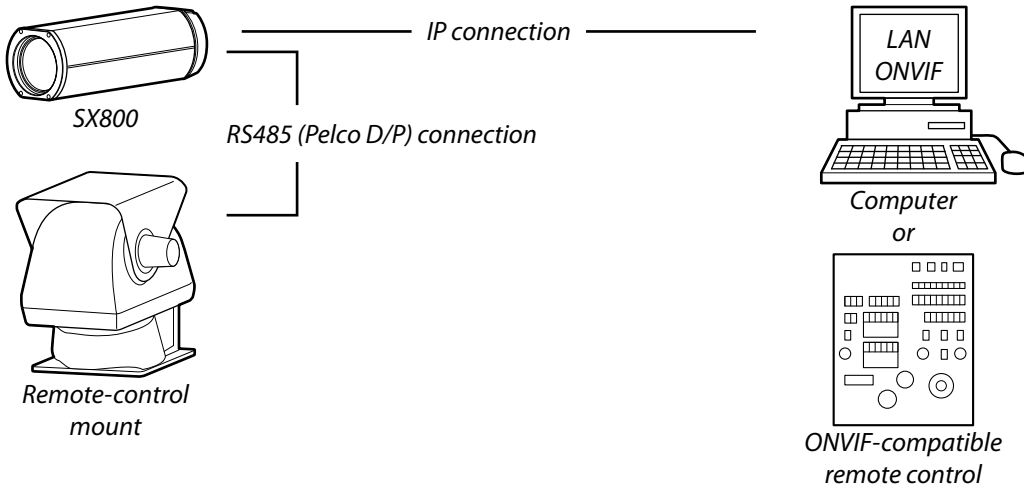

When the camera is connected to a computer via Internet protocols (IP), a web browser can be used to adjust camera settings and an ONVIF application to view the live feed and control the camera.

Operating Mode Selection: DIP Switches

Use the DIP switches to select the operating mode.

Operating mode	DIP switch			
	①	②	③	④
LAN ONVIF	OFF	ON	OFF	OFF
RS485	ON	OFF	OFF	OFF
Stand-alone	ON	ON	OFF	OFF

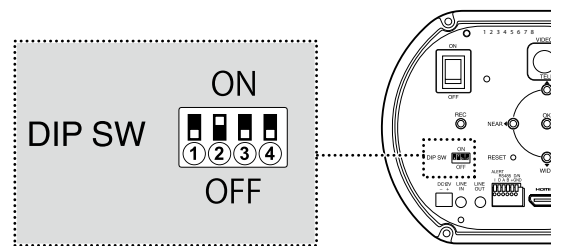

Connecting to a Computer

- 1 Connect the supplied plug to the power cable and plug the cable into the camera power connector.

CAUTION Use only DC 12 V power.

TIP Customers must supply their own power cable.

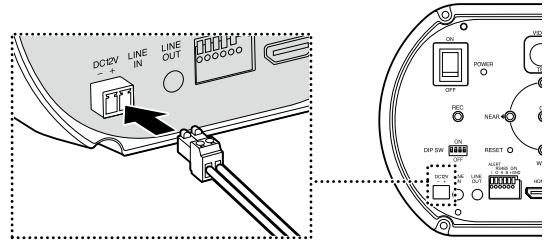

- 2 Use an Ethernet cable to connect the camera to a computer.

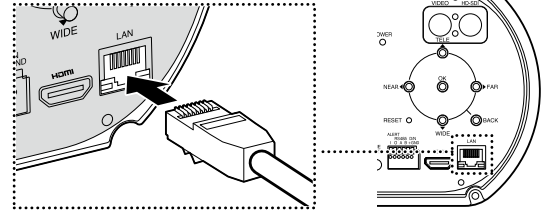

- 3 Select LAN ONVIF by setting DIP switch ② to "ON" and DIP switches ①, ③ and ④ to "OFF".

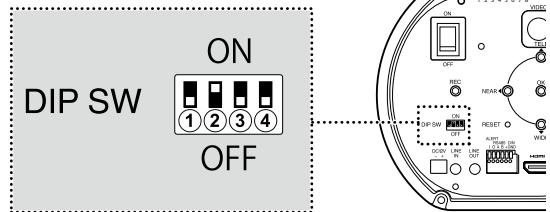

- TIPS**
- For information on connecting control units or remote-control mounts, see the *Command List*.
 - For information on using control units or remote-control mounts, see the documentation provided with the device.

Viewing and Recording the Live Feed

The camera's live feed can be viewed and recorded using a web browser.

Launching a Web Browser

Supported operating systems	Windows 7, Windows 10
Supported web browsers	Internet Explorer 11, Google Chrome 71 or later

For information on using the web browser, see the browser's online help. To connect to the SX800, you will need to assign it an appropriate IP address. The default IP address and subnet mask assigned to the camera at shipment are as follows:

IP address	192.168.1.10
Subnet mask	255.255.255.0

- 1 Turn on the camera and computer.
- 2 Launch a web browser.
- 3 Enter the product IP address in the address bar ("http://[IP address]").
An administrator account creation dialog will be displayed.
- 4 Enter a user name, password, and client IP address.
At shipment, the user name, password, and IP address fields are blank.

- Choose a password 8 to 15 characters long. Take all steps necessary to protect the password.
- After 10 failed attempts, password entry will lock. The camera must then be re-initialized in stand-alone mode as described below.

Note that this deletes all existing accounts.

- ① Turn the camera off.
- ② Select stand-alone mode using the DIP switches on the rear control panel (page 7).
- ③ Turn the camera on.
- ④ Press and hold the **OK/MENU** button on the rear control panel for 3 seconds to display the menus.
- ⑤ Select **IP ADDRESS SETTINGS RESET** in the setup menu.
- ⑥ Turn the camera off and return to Step 3 of "Operating Mode Selection: DIP Switches" (page 7).

Note: For more information, see the *Owner's Manual: Stand-Alone Mode*.

TIPS

- 5 Click **OK**.
Camera settings will be displayed.

ADMINISTRATOR

USER NAME

PASSWORD

RE-ENTER PASSWORD

IPv4 ADDRESS

SHOW PASSWORD

Please set password from 8 to 15 characters. *No blank spaces.

OK

Preferences

Adjust camera settings.

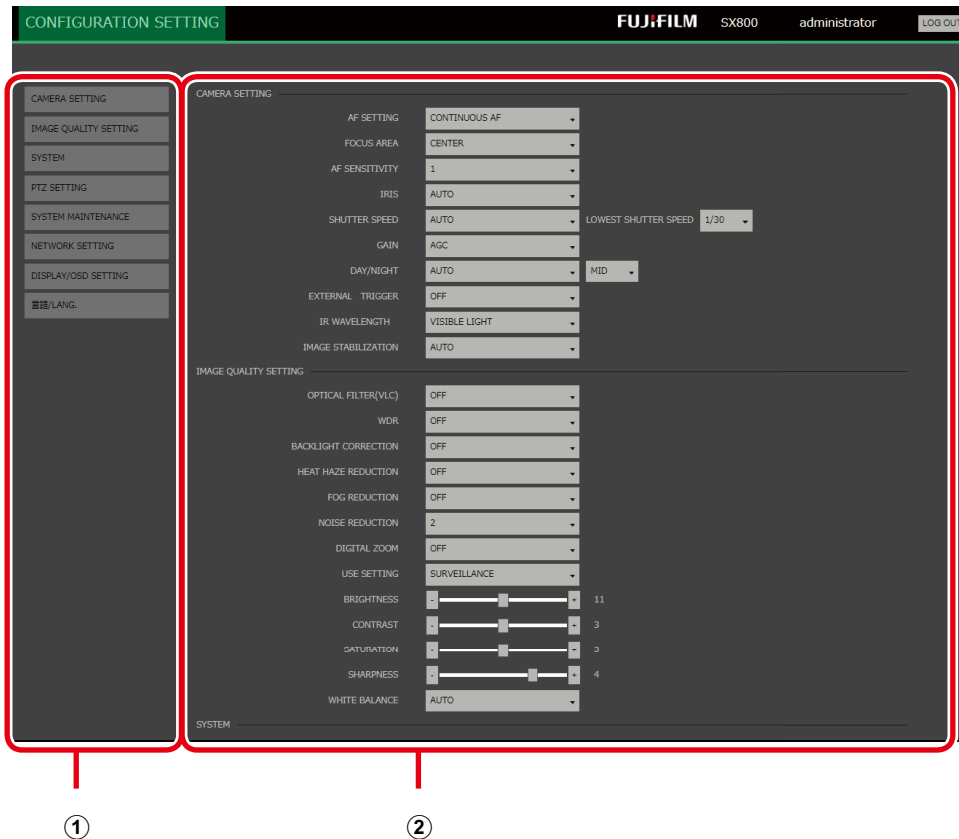

Choosing a category (①) displays the associated settings (②).

Category	Description
CAMERA SETTING	Adjust basic camera settings.
IMAGE QUALITY SETTING	Adjust image quality settings.
SYSTEM	View the firmware version and other information. You can also set the camera clock and adjust other system-related settings.
PTZ SETTING	Adjust settings for remote-control mounts.
SYSTEM MAINTENANCE	Restart the camera, update camera firmware, and perform other forms of system maintenance.
NETWORK SETTING	Adjust basic network settings.
DISPLAY/OSD SETTING	Adjust display settings.
言語/LANG.	Choose a language for camera menus and displays.

CAUTION Do not insert or remove memory cards while the camera is on. Failure to observe this precaution could corrupt image files or damage the memory card.

CAMERA SETTING

Adjust basic camera settings.

AF SETTING

Choose how the camera focuses when autofocus is enabled via ONVIF.

Options		
CONTINUOUS AF	QUICK AF	ONE PUSH AF

FOCUS AREA

Choose how the camera selects the focus area when **CONTINUOUS AF** is selected for **AF SETTING**.

Option	Description
CENTER	The camera focuses on the subject at the center of the frame.
AREA	The frame is divided into a three-by-three grid for focus-area selection.

AF SENSITIVITY

Choose how long the focus system will continue to track the current subject after a new subject enters the frame at a different distance from the camera. The higher the value, the longer the camera will wait before switching subjects.

IRIS

Choose the aperture value (iris). See "Specifications" (page 23) for supported values.

SHUTTER SPEED

Choose the shutter speed.

Option	Description
AUTO	The camera adjusts shutter speed automatically. You can choose the minimum shutter speed.
MANUAL	Choose the shutter speed manually.

GAIN

Adjust image brightness.

Option	Description
MANUAL	Choose a value for gain.
AGC	The camera adjusts gain automatically to brighten the image when lighting is poor.
HYPER-AGC	Choose for automatic gain control adapted to low light conditions.

DAY/NIGHT

In day/night mode, the camera records in color when the subject is brightly lit and in black-and-white when the subject is poorly lit. This option is available when **OFF** is selected for both **EXTERNAL TRIGGER** and **OPTICAL FILTER (VLC)**.

Option	Description
AUTO	The camera selects day or night mode automatically according to lighting conditions. You can choose the brightness level that triggers the switch: <ul style="list-style-type: none"> • DARK: The switch is triggered when lighting is comparatively dark. • MID: The switch is triggered at light levels between DARK and BRIGHT. • BRIGHT: The switch is triggered when lighting is comparatively bright.
DAY	The camera operates in day (color) mode at all times.
NIGHT	The camera operates in night (black-and-white) mode at all times.

 **TIP** The **CAMERA SETTING > DAY/NIGHT, EXTERNAL TRIGGER, and IR WAVELENGTH** and the **IMAGE QUALITY SETTING > OPTICAL FILTER (VLC)** preferences are linked. For more information, see “Lighting Triggers” (page 13).

EXTERNAL TRIGGER

Choose whether day/night selection is performed in response to an external trigger.

Option	Description
ON (VLC)	Applies a VLC (Visible Light Cut) filter to the external trigger. CAMERA SETTING > DAY/NIGHT and IMAGE QUALITY SETTING > OPTICAL FILTER (VLC) are disabled.
ON (CLEAR)	Replaces the filter with clear glass. CAMERA SETTING > DAY/NIGHT and IMAGE QUALITY SETTING > OPTICAL FILTER (VLC) are disabled.
OFF	The camera does not respond to the external trigger.

 **TIP** The **CAMERA SETTING > DAY/NIGHT, EXTERNAL TRIGGER, and IR WAVELENGTH** and the **IMAGE QUALITY SETTING > OPTICAL FILTER (VLC)** preferences are linked. For more information, see “Lighting Triggers” (page 13).

IR WAVELENGTH

Match the IR wavelength to the infrared light source used. See “Specifications” (page 23) for supported values.

 **TIP** The **CAMERA SETTING > DAY/NIGHT, EXTERNAL TRIGGER, and IR WAVELENGTH** and the **IMAGE QUALITY SETTING > OPTICAL FILTER (VLC)** preferences are linked. For more information, see “Lighting Triggers” (page 13).

IMAGE STABILIZATION

Choose an image stabilization option adapted to the scene.

Option	Description
AUTO	The camera chooses the type of image stabilization best suited to the scene.
OIS	Reduce the effects of camera shake using optical image stabilization.
EIS	Reduce the effects of camera shake using electronic image stabilization.
OFF	Image stabilization disabled.

Lighting Triggers

Day/night selection can be configured in any of the following three ways:

Configuration	Description	Configured using	
		Menu item	Option
① Auto	Day/night selection is performed automatically in response to lighting conditions.	CAMERA SETTING > DAY/NIGHT	AUTO
② Manual	Day/night selection is performed manually.		DAY or NIGHT
③ External trigger	Day/night selection is performed in response to input from an external trigger.	CAMERA SETTING > EXTERNAL TRIGGER	ON (VLC) *, ON (CLEAR) *, or OFF

* The option selected for **OPTICAL FILTER (VLC)** does not apply if a signal is received from the external trigger when **ON (VLC)** or **ON (CLEAR)** is selected for **EXTERNAL TRIGGER**. If no signal is received or if **OFF** is selected, the optical filter will function as shown in the following table.

The following table shows relation between the option selected for **OPTICAL FILTER (VLC)** and the filter type, image color, and wavelength when day/night selection is enabled:

Option	CONFIGURATION SETTING > IMAGE QUALITY SETTING > OPTICAL FILTER (VLC)	Filter	Image color	CONFIGURATION SETTING > CAMERA SETTING > IR WAVELENGTH	
				Status	Supported wavelengths
DAY	OFF	IRCF	Color	Disabled	Visible light only
	ON	VLCF			808 nm only
NIGHT	OFF	CLEAR	Black and white	Enabled	950 nm, 940 nm, 850 nm, 808 nm, visible light
	ON	VLCF			

IMAGE QUALITY SETTING

Adjust image quality settings.

OPTICAL FILTER (VLC)

Enable or disable the VLC (Visible Light Cut) filter.

Option	Description
ON	Enable the VLC filter, blocking visible light and recording only infrared footage.
OFF	Enable the clear (CLEAR) or infrared cut-off filter (IRCF).

 **TIP** The CAMERA SETTING > DAY/NIGHT, EXTERNAL TRIGGER, and IR WAVELENGTH and the IMAGE QUALITY SETTING > OPTICAL FILTER (VLC) preferences are linked. For more information, see “Lighting Triggers” (page 13).

WDR

Reduce loss of detail in highlights and shadows. Choose higher values for high-contrast subjects.

BACKLIGHT CORRECTION

Reduce loss of detail in the shadowed areas of backlit subjects. The higher the value, the greater the effect.

HEAT HAZE REDUCTION

Reduce the wavering effect of heat haze, making the image clearer overall. The higher the value, the greater the effect.

FOG REDUCTION

Make images where the subject is obscured by fog more vivid and easier to see. The higher the value, the greater the effect.

NOISE REDUCTION

Reduce the effects of noise for a smoother picture. The higher the value, the greater the effect.

DIGITAL ZOOM

Select ON to enable digital zoom.

USE SETTING

Choose a shooting preset.

Option	Description
SURVEILLANCE	Emphasize outlines.
MOVIE PRODUCTION	Choose for accurate color reproduction when shooting non-surveillance footage at social gatherings or other events.

BRIGHTNESS

Adjust brightness. The higher the value, the greater the effect.

CONTRAST

Adjust contrast. The higher the value, the greater the effect.

SATURATION

Adjust color saturation. The higher the value, the greater the effect.

SHARPNESS

Make outlines more or less sharply defined. The higher the value, the greater the effect.

WHITE BALANCE

Match white balance to the light source (for example, sunlight or artificial lighting).

Option	Description
AUTO	The camera adjusts white balance automatically.
CUSTOM 1/CUSTOM 2	Measure a value for white balance using a piece of paper or other white reference object.
FINE	For subjects lit by direct sunlight.
SHADE	For subjects in the shade or under overcast skies.
COLOR TEMPERATURE	Choose a color temperature (3000K, 5000K, or 9000K).

SYSTEM

View the firmware version and other information. You can also set the camera clock and adjust other system-related settings.

MODEL NAME

View the camera model name.

SERIAL NO.

View the product serial number.

FW VER.

View the camera firmware version.

APPLICATION VER.

View the application version.

TIME ZONE

Choose a time zone.

IN-CAMERA TIME SETTING

Set the camera clock.

ABOUT DEVICE

View OSS information.

PTZ SETTING

Adjust settings for remote-control mounts.

 **TIP** You will need to turn the camera off and then on again after adjusting settings in this menu.

RS485 BAUD RATE

Choose the baud rate for data transmitted via RS485.

Options					
115200bps	38400bps	19200bps	9600bps	4800bps	2400bps

RS485 ID

Choose the RS485 ID (1–31).

RS485 TERMINATION

Select **ON** to enable the RS485 termination resistor.

Pelco-P/Pelco-D

Choose a communications protocol.

SYSTEM MAINTENANCE

Restart the camera, update camera firmware, and perform other forms of system maintenance.

REBOOT

Select **OK** to restart the camera.

RESET SETTINGS

Select **OK** to restore camera settings to their default values. Items in the following menus are not affected:

- NETWORK SETTING

IMPORT CONFIGURATION FILE

Import settings from a camera settings file. Click **BROWSE** and choose a settings file created using **EXPORT TO CONFIGURATION FILE**.

EXPORT TO CONFIGURATION FILE

Export camera settings. Click **OK** to download the settings folder.

FW UPDATE

Update the camera firmware. Click **BROWSE** and select the file containing the new firmware version to begin the update.

COPY LOG DATA

Save a copy of camera logs. Click **BROWSE**, choose a destination, and click **OK** to save the logs.

NETWORK SETTING

Adjust basic network settings.

IPv4 ADDRESS

Enter the camera's IPv4 address.

IPv4 SUBNET MASK

Enter the camera's IPv4 subnet mask.

IPv4 DEFAULT GATEWAY

Enter the camera's default IPv4 gateway.

MAC ADDRESS

View the camera's MAC address.

IPv4 MTU

Choose the maximum volume of data that can be transmitted per packet (frame).

PRIORITY DNS SERVER

Enter the IP address of the primary DNS server.

SECONDARY DNS SERVER

Enter the IP address of the secondary DNS server.

IPv4 ADDRESS

Choose how the camera's IPv4 address is assigned.

Option	Description
DISABLE	The camera is not assigned an IPv4 address.
MANUAL	Enter the camera's IPv4 address manually.
AUTO (DHCP)	Enable automatic IPv4 address allocation via the Dynamic Host Configuration Protocol (DHCP).

DISPLAY/OSD SETTING

Adjust display settings.

DATE DISPLAY

Select **ON** to show the date in the live feed.

TIME DISPLAY

Choose whether times are displayed using a 12- or 24-hour clock.

DATE DISPLAY FORMAT

Choose the order in which the year, month, and day are displayed.

言語/LANG.

Choose a language for camera menus and displays.

言語/LANG.

Choose a language.

Troubleshooting

Should the product fail to function as expected, consult the table below. If you are unable to find a solution here, contact your local Fujifilm distributor.

Problem	Solution
No video, or the image in the video is dark.	<ul style="list-style-type: none">• The camera is off: Check that the cables are correctly connected, the power lamp is lit, and the correct voltage is being supplied to the lens.• The cables are not correctly connected: Check that the cables are correctly connected.• The lens cap is on: Remove the lens cap.• The iris is stopped down to the minimum aperture: Select maximum aperture.• Shutter speed requires adjustment: Select an appropriate value for shutter speed.
The image in the video is “washed out”.	<ul style="list-style-type: none">• Camera white balance, gain, shutter speed, or other settings require adjustment: Confirm that settings are adjusted appropriately.• Aperture requires adjustment: Adjust aperture appropriately.
The image in the video is out of focus. Spots appear in the video.	<ul style="list-style-type: none">• The lens is dirty: Clean the lens.

Defaults

Selecting OK for SYSTEM MAINTENANCE > RESET SETTINGS restores settings to the following default values:

CAMERA SETTING

Option	Default
AF SETTING	CONTINUOUS AF
FOCUS AREA	CENTER
AF SENSITIVITY	1
IRIS	AUTO
SHUTTER SPEED	AUTO (1/30)
GAIN	AGC
DAY/NIGHT	AUTO (MID)
EXTERNAL TRIGGER	OFF
IR WAVELENGTH	VISIBLE LIGHT
IMAGE STABILIZATION	AUTO

IMAGE QUALITY SETTING

Option	Default
OPTICAL FILTER (VLC)	OFF
WDR	OFF
BACKLIGHT CORRECTION	OFF
HEAT HAZE REDUCTION	OFF
FOG REDUCTION	OFF
NOISE REDUCTION	2
DIGITAL ZOOM	OFF
USE SETTING	SURVEILLANCE
BRIGHTNESS	11
CONTRAST	3
SATURATION	3
SHARPNESS	4
WHITE BALANCE	AUTO

SYSTEM

Option	Default
MODEL NAME	—
SERIAL NO.	—
FW VER.	—
APPLICATION VER.	—
TIME ZONE	—
IN-CAMERA TIME SETTING	—
ABOUT DEVICE	—

PTZ SETTING

Option	Default
RS485 BAUD RATE	9600bps
RS485 ID	7
RS485 TERMINATION	ON
Pelco-P/Pelco-D	Pelco-D

SYSTEM MAINTENANCE

Option	Default
REBOOT	—
RESET SETTINGS	—
IMPORT CONFIGURATION FILE	—
EXPORT TO CONFIGURATION FILE	—
FW UPDATE	—
COPY LOG DATA	—

NETWORK SETTING

Option	Default
IPv4 ADDRESS	192.168.1.10
IPv4 SUBNET MASK	255.255.255.0
IPv4 DEFAULT GATEWAY	192.168.1.254
MAC ADDRESS	—
IPv4 MTU	1500
PRIORITY DNS SERVER	192.168.1.254
SECONDARY DNS SERVER	—
IPv4 ADDRESS	MANUAL

DISPLAY/OSD SETTING

Option	Default
DATE DISPLAY	ON
TIME DISPLAY	24H
DATE DISPLAY FORMAT	MM-DD-YYYY

言語/LANG

Option	Default
言語/LANG	ENGLISH

Specifications

Model	FUJIFILM SX800
Focal length	20–800 mm
Optical zoom	40×
Digital zoom	1.25×
Iris range	f/4–f/16
Minimum object distance (M.O.D.)*	10 m “at focal lengths of 20–400 mm” 20 m “at focal lengths of 401–800 mm”
Image sensor	CMOS sensor
Video	<ul style="list-style-type: none"> • File format: MOV • Video compression: H.264 compliant • Audio recording format: Linear PCM stereo (48 kHz sampling)
Frame size	1920 × 1080, 1280 × 720, 640 × 480 (NTSC), 768 × 576 (PAL)
Metering	Average
Focus modes	Continuous AF, quick AF, MF
Aperture selection	Auto, f/4–f/16
Shutter speed	Auto (with minimum speed selection of 1/8 – 1/125 s), manual (1 – 1/20000 s)
Gain adjustment	Manual (ISO 400 – ISO 819200), AGC, HYPER AGC
Day/night selection	Auto, manual
Wavelengths	VISIBLE LIGHT, 950 nm, 940 nm, 850 nm, 808 nm
Image stabilization	Available (AUTO, OIS, EIS, OFF)
Wide dynamic range	Selectable (2 levels)
Back light compensation	Selectable (2 levels)
Heat haze reduction	Selectable (3 levels)
Fog reduction	Selectable (3 levels)
Noise reduction	Selectable (3 levels)
Shooting Mode Preset	Surveillance, movie production
Brightness	Selectable (21 levels)
Contrast	Selectable (5 levels)
Saturation	Selectable (5 levels)
Sharpening	Selectable (5 levels)
White balance	Auto, Custom 1–2, fine, shade, color temperature (degrees Kelvin) selection (3000K, 5000K, 9000K)
Video format	1080p, 720p, 480p/576p
Image output connectors	HDMI, HD-SDI, composite (BNC)
Audio input/output	<ul style="list-style-type: none"> • Input impedance: 40KΩ • Output impedance: 200Ω
Video output	<ul style="list-style-type: none"> • NTSC: 1080p, 720p, 480p • PAL: 1080p, 720p, 576p
External interface	100BASE-T, RS-485, external trigger (day/night selection)
Internet protocol	ONVIF
RS-485 protocol	Pelco D, P (includes custom commands)
Power source	DC 12 V
Power consumption	9.5 W
Dimensions (W × H × D)	156 mm × 139 mm × 410 mm/ 6.14 in. × 5.47 in. × 16.14 in.
Weight	Approx. 6.4 kg/14.11 lb
Operating environment	<ul style="list-style-type: none"> • Temperature: –10 °C – +50 °C/+14 °F – +122 °F • Humidity: 10% – 80% (no condensation)
Tilt limit	±45° from level (base down)

* From the foremost part of the forward lens

FUJIFILM

FUJIFILM Corporation Optical Device & Electronic Imaging Products Div.
1-324 Uetake, Kita-ku, Saitama City, Saitama 331-9624, Japan
TEL. 81-48-668-2143 FAX. 81-48-651-8517
<http://www.fujifilm.com/>

HDMI[®]
HIGH DEFINITION MULTIMEDIA INTERFACE